

M519 Data Sheet and Hardware Integration Guide

Headquarters, Europa

SpringCard SAS
2, voie la Cardon
Parc Gutenberg
91120 Palaiseau
FRANCE

Phone: +33 (0)1 64 53 20 10

Americas

SpringCard Inc.
185 Alewife Brook Parkway,
ste 210
Cambridge, MA 02138
USA

Email: sales@springcard.com

www.springcard.com

Document Identification

Category	Datasheets
Group/Family	SpringCore / M519
Reference & Version	PFT22217-AB
Date	
Diffusion	Public
Keywords	M519

Revision History

Version	Date	Author	QC	Description
00	07/11/2022	JDA		Draft preview
AA	16/08/2023	JDA	CFE	First public release (but still with a lot of <i>TBD</i>)
AB	18/09/2023	JDA	CFE	Added reference schematics in chapters 7, 8 and 9

Table of Contents

1	Introduction.....	5
1.1	Overview.....	5
1.2	Related documents.....	5
1.3	Order codes.....	6
2	About the SpringSeed M519.....	7
2.1	General description.....	7
2.2	Features and benefits.....	8
2.3	Typical applications.....	9
2.4	Integration, development and ready-to-use derived products.....	10
3	Technical data.....	11
3.1	General.....	11
3.2	NFC/RFID HF (contactless) Interface.....	12
3.3	Smart card (contact) Interface.....	13
3.4	Host Interfaces.....	13
4	Mechanical specification.....	14
4.1	Dimensions and location of the pins.....	14
4.2	Pinout.....	15
4.3	Recommended PCB layout.....	18
4.4	Tape and reel packaging.....	19
5	Electrical specification.....	20
5.1	Limiting values.....	20
5.2	Power.....	21
5.3	VOUT pin.....	22
5.4	SC_VCC pin.....	22
5.5	/RESET, /SUSPEND, /SC_IRQ pins.....	23
5.6	/FLASH, MODE0, MODE1 pins.....	23
5.7	RX, PER_RX pins.....	23
5.8	TX, PER_TX, /PER_EN, /WAKEUP, SC_RST, SC_CLK, I2C_SCL pins.....	24
5.9	SC_IO, /PER_CS, PER_CLK, I2C_SDA pins.....	24
5.10	GPIO1, GPIO2, GPIO3, GPIO4, GPIO5 pins.....	25
6	Application information.....	26
6.1	Operating modes, profiles and protocols.....	26
6.2	Bootloader, firmware upgrade.....	30
6.3	Reset configuration and MODE0, MODE1 pins.....	31
6.4	Serial shell.....	33
6.5	Configuring the M519.....	34
7	Integration Guide – Host Interface and power supply.....	37

- 7.1 USB..... 37
- 7.2 Serial..... 42
- 8 Integration Guide – RF antenna..... 44
 - 8.1 Static matching circuit..... 44
 - 8.2 “Auto-tune” matching circuit..... 45
 - 8.3 Reference PCB layouts and BOMs..... 47
 - 8.4 Configuring the M519 for the actual antenna..... 52
 - 8.5 In-the-field RF optimization..... 53
- 9 Integration Guide – Contact smart card..... 54
 - 9.1 Single slot, direct access..... 55
 - 9.2 Single ID-000 slot, using TDA8035..... 57
 - 9.3 One ID-1 and four ID-000 slots, using TDA8026..... 59
 - 9.4 Smart card interface detection algorithm..... 65

1 Introduction

1.1 Overview

This document describes the functionalities and electrical specifications of the SpringCard SpringSeed M519 OEM NFC/RFID HF module, using firmware version 1.30 or higher.

1.2 Related documents

1.2.1 Documents available as PDF

Reference	Title / Description
PMD23175	M519-SRK Getting Started Guide
PNA23174	Using the M519 in PC/SC Coupler mode over a Serial interface
PNA23207	Using the M519 in PC/SC Coupler mode over a USB interface
PNA23208	Using the M519 in Smart Reader or RFID Scanner mode
PNA23189	Using the M519 in SpringProx Legacy mode

1.2.2 Online material

Documentation of the SpringCore firmware.

<https://docs.springcard.com/books/SpringCore/Welcome>

SpringCard Tech Zone, the blog of the R&D Team

<https://tech.springcard.com/>

1.3 Order codes

Order code	Model	MOQ
SC23076	M519 (cut reel)	10 pieces
SC23218	M519, reel of 500 units	1 reel (500 pieces)

2 About the SpringSeed M519

2.1 General description

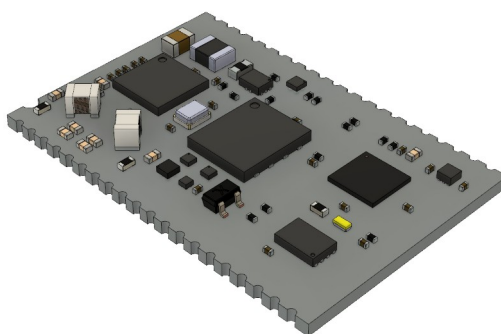

Figure 1: 3D view of the M519

The SpringCard SpringSeed M519 is a versatile OEM NFC/RFID HF module.

The M519 is designed to be used in industrial equipments or consumer devices, and has to be connected to an external antenna through a “mother board” PCB.

The M519 is able to communicate with virtually any contactless smart card, RFID label, NFC tag or NFC smartphone compliant with one of the standard technologies in the 13.56MHz range.

The M519 features a contact smart card interface, that is able to drive either one SAM card (ID-000) either directly or through a NXP TDA8035 IC, or to drive up to 5 ID-1 and ID-000 slots through a NXP TDA8026 IC.

The M519 also features a protected storage for secret and private cryptographic keys, and is able to run secure transactions protected by AES or ECC schemes with contactless cards and NFC smartphones.

The M519 is either a Serial device or a USB device; it operates either in Coupler mode (reader/writer, APDU level) or in Smart Reader mode, freeing the host from all technical aspects of the transaction with the cards.

The M519 may either be surface-mounted on its “mother board” PCD using the edge-plated pads, or be soldered on 0.50" (1.27mm) headers using Ø0.6 half-holes on the outline.

2.2 Features and benefits

2.2.1 Ease of integration into any hardware

- Smallest design on the market (26.67 x 17.78 x 2.6 mm or 1.05 x 0.7 x 0x10 "),
- Components mounted on the top side only, bottom pads and castellated edges ready for either SMD or THT mounting,
- NXP PN5190 NFC/RFID HF frontend allowing best in-class performance/power ratio,
- Self-antenna tuning capability,
- Single-source power supply, power saving modes, low power card detection features on less than 5µA,
- ISO 7816 interface supporting up to 4 external SIM/SAM (ID-000) slots and 1 ID-1 smart card slot.

2.2.2 Ease of integration for any application and use case

- Serial interface supporting a various choice of protocols, making it easy to operate the module even from low-end MCUs,
- USB interface supported by Linux (even low-end embedded SOCs), Windows and macOS,
- In-the-field configuration and firmware upgrade (flash) without interruption,
- Comprehensive starter kit and a wide range of SDK and samples available for free on GitHub,
- Compliant with earlier SpringCard SDKs and software libraries (PC/SC, SpringProx, etc).

2.2.3 Open and interoperable

- Standard-compliant USB CCID (PC/SC) and USB HID keyboard wedge (RFID Scanner) profiles,
- Digital layer of the Contactless stack pre-validated against the following test suites¹:
 - EMV CL L1,
 - NFC Forum CR12 and CR13,
 - CEN/TS 16794 aka ISO/IEC/TS 24192, RCTIF 5,
- Digital layer of the Contact stack pre-validated against the EMV CT L1 test suite²,
- Support of Apple Pay ECP1 and ECP2 for Passkit / Apple VAS applications, support of Google Smart Tap,
- Support of NXP Mifare and NTAG families, the largest portfolio of contactless cards.

2.3 Typical applications

- Public transport, public bike systems, car sharing,
- Car-park gates or cashiers,
- Kiosk, vending machines,
- Mobile or affixed terminals for loyalty, events, gaming...
- Access control, secure identification,
- and more.

1 Actual conformance (Digital and Analogue layers) depends on the antenna, on the hardware integration and on the configuration; complete validation must be performed on the assembled product. Contact us for expertise should you need to pass a certification.

2 Actual conformance (including the Analogue layer) depends on the electrical card interface, on the hardware integration and on the configuration; complete validation must be performed on the assembled product. Contact us for expertise should you need to pass a certification.

2.4 Integration, development and ready-to-use derived products

The M519-SRK is a complete Starter Kit for customers who want to evaluate the M519 module and then build their own solution around it. It makes it easy for integration and development engineers to get to grips with the module. See [PMD23175] for details.

The SpringSeed M519 OEM module is the core component of the SpringCard M519-SUV, a ready-to-use NFC/RFID HF OEM product (module + antenna with USB and Serial connectors). See [PMI23209] for details.

3 Technical data

3.1 General

Dimensions	26.67 x 17.78 x 2.6 mm
Weight	Approx. 7g
Power supply	3.3V nominal for Serial operation 5V (powered by the bus) for USB operation
Power requirement	Nominal: 200mA Max: 400mA Power saving: < 1mA
Temperature range	Operating temperature: -20 to +70°C Storage temperature: -20 to +70°C
Environment	Humidity 0 – 90% (non condensing)

3.2 NFC/RFID HF (contactless) Interface

3.2.1 Coupler and Smart Reader operation

NFC/RFID HF carrier	13.56MHz
Antenna requirement	External antenna, 20Ω-matched, balanced
Operating distance	Up to 100mm depending on antenna, card and environment
RF power	Max 2W
Supported standards	ISO/IEC 14443 A & B (PCD) / NFC-A and NFC-B ISO/IEC 15693 (VCD) and ISO/IEC 18000-3M1 / NFC-V ISO/IEC 18000-3M3 (RFID HF) / EPC HF JIS X 6319-4 / NFC-F ISO/IEC 21481 (NFCIP-2)
Bitrates	26, 53, 106, 212, 424, 848 kbit/s depending on the protocol NFC Forum types 1, 2, 3, 4 and 5 Mifare Classic with CRYPTO1 All cards in NXP Mifare families: Mifare Plus, Mifare UltraLight, Desfire, All cards in NXP NTAG and ICODE families Innovatron (Calypso cards)
Supported card technologies (partial list)	STMicroElectronics SR & LR Infineon SLE44, SLE66, SRF55 Texas Instrument Tag-it Sony FeliCa Lite Apple ECP, Apple VAS (PassKit NFC), Google Smart Tap and other NFC applications on smartphones Inside Secure PicoPass / HID iClass (ID only)
Advanced features	Low power card detection Automatic waveform control

3.2.2 Card emulation and peer-to-peer operation

Supported standards	ISO/IEC 14443 A (PICC) / emulation of NFC Forum Type 4A Tag ISO/IEC 18092 (NFCIP-1) active and passive, initiator and target
Bitrates	106, 212, 424 kbit/s depending on the protocol

3.3 Smart card (contact) Interface

Card clock	4MHz
Card power class	Direct on M519: 3.3V (class B) Through TDA8026 or TDA8035: 1.8V, 3.3V or 5V (classes A, B, C)
Supported standards	ISO/IEC 7816-3, 7816-4
Bitrates	TA1= _H 11 (10752bps) to TA1= _H 96 (250kbps)

3.4 Host Interfaces

3.4.1 USB

Standard	USB 2.0 device, compatible with USB 3
Bitrate	Full speed (12Mbps)
Profiles	CCID (PC/SC) HID keyboard CDC-ACM (serial emulation) SpringCore Direct

3.4.2 Serial

Physical interface	RX/TX @ 0/3.3V (compliant with TTL & CMOS peers) 8 data bits, 1 stop bit, no parity, no flow control
Bitrate	38400bps (default), up to 500kbps after handshaking
Protocols	CCID over Serial SpringProx Legacy SpringCore Direct RDR MK1 \$SCRDR

4 Mechanical specification

4.1 Dimensions and location of the pins

The M519 is a single-sided PCB with dual castellated/through-hole pins around the edges. It is designed to be usable as a surface mount module as well as being in Dual Inline Package (DIP) type format, with the 40 main pins on a 1.27mm (0.05") pitch grid with 0.6mm holes.

A 1.2mm half-hole on the left-hand side of the north-bound edge acts as a *poka yoke* (polarizer) to let the pick and place machine know where pin #1 is.

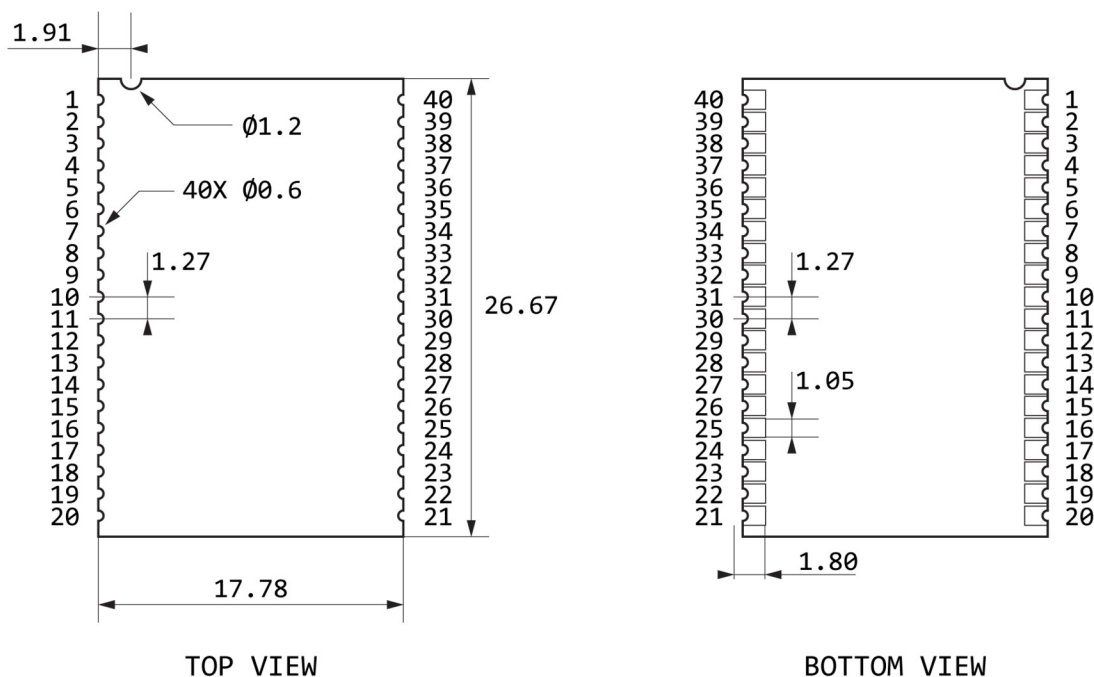

ALL DIMENSIONS IN MILLIMETERS
 PRINT VERSION NOT TO SCALE
 (APPROX 2:1)
 OUTLINE TOLERANCE $\pm 0.25\text{MM}$ - TOLERANCE ON DRILLING $\pm 0.05\text{MM}$
 LOCATION OF PADS ACCORDING TO IPC-A-600 CLASS 2

Figure 2: Mechanical specifications

4.2 Pinout

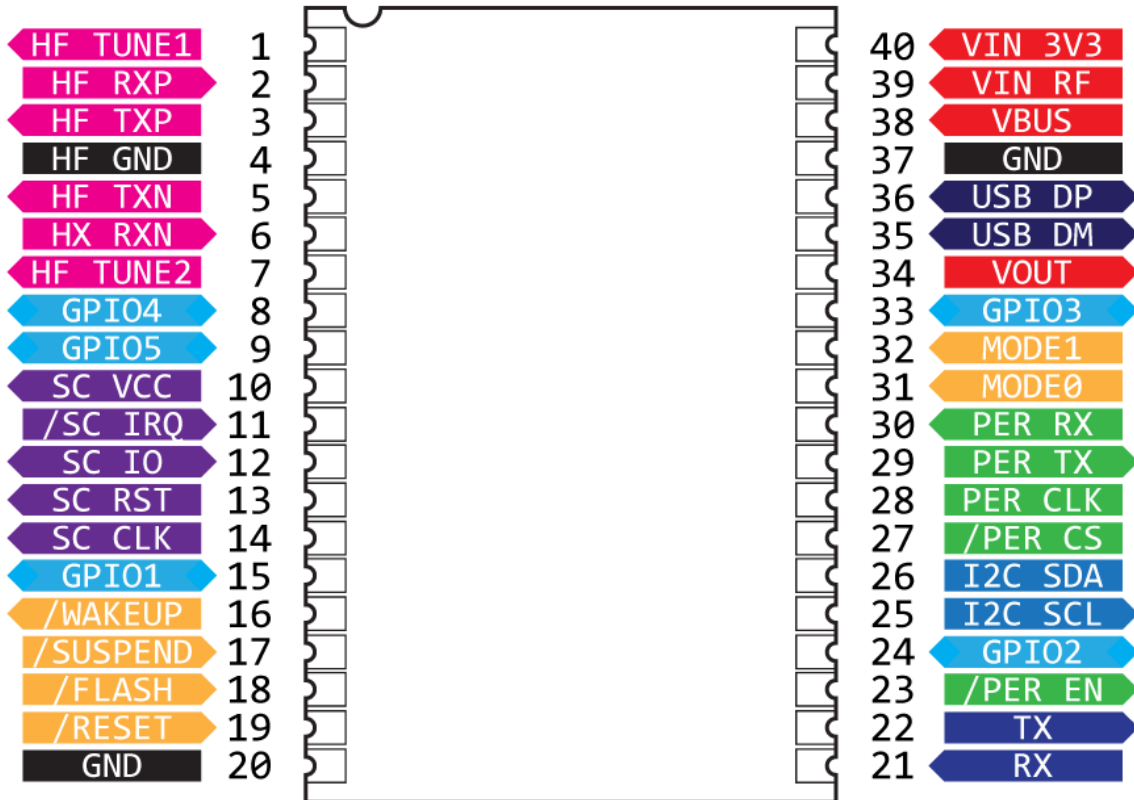

■ POWER
 ■ GROUND
 ■ NFC/RFID HF
 ■ SMART CARD
■ GPIO
 ■ I2C MASTER
 ■ ALT UART/SPI MASTER/SPI SLAVE
 Host interface:
■ SERIAL
 ■ USB
 ■ CONTROL/CONFIG/STATUS

Figure 3: Pinout of the module

4.2.1 West-bound header

Pin	Symbol	Type	Description
# 1	HF_TUNE1	Analog	Antenna self-tuning capacitor 1
# 2	HF_RXP	Analog	Antenna receiver (plus side)
# 3	HF_TXP	Analog	Antenna driver (plus side)
# 4	HF_GND	Analog	Antenna ground
# 5	HF_TXP	Analog	Antenna driver (minus side)
# 6	HF_RXN	Analog	Antenna receiver (minus side)
# 7	HF_TUNE2	Analog	Antenna self-tuning capacitor 2
# 8	GPIO4	In/Out	
# 9	GPIO5	In/Out	
# 10	SC_VCC	Out	Card VCC signal
# 11	/SC_IRQ	In	Card status / TDA8026 interruption
# 12	SC_IO	In/Out	Card I/O signal
# 13	SC_RST	Out	Card RST signal
# 14	SC_CLK	Out	Card CLK signal (4MHz) / TDA8026 master clock (16MHz)
# 15	GPIO1	In/Out	
# 16	/WAKEUP	Out	Tell the host that the module is active
# 17	/SUSPEND	In	Tell the module to enter standby mode
# 18	/FLASH	In	Force DFU (bootloader) mode upon reset
# 19	/RESET	In	Reset the module
# 20	GND	Ground	

4.2.2 East-bound header

Pin	Symbol	Type	Description
# 21	RX	In	Main UART, host to module
# 22	TX	Out	Main UART, module to host
# 23	/PER_EN	Out	Activate the peripherals
# 24	GPIO2	In/Out	
# 25	I2C_SCL	Out	I ² C SCL (master)
# 26	I2C_SDA	In/Out	I ² C SDA (master)
# 27	/PER_CS	In/Out	SPI chip select
# 28	PER_CLK	In/Out	SPI clock
# 29	PER_TX	Out	TX to peripherals
# 30	PER_RX	In	RX from peripherals
# 31	MODE0	In	Configure operating mode
# 32	MODE1	In	Configure operating mode
# 33	GPIO3	Out	
# 34	VOUT	Out	3.3V output, max 100mA, to power the peripherals
# 35	USB_DM	USB	USB D- signal
# 36	USB_DP	USB	USB D+ signal
# 37	GND	Ground	
# 38	VBUS	USB	Digital power supply + USB presence, 5V
# 39	VIN_RF	Power	Power supply for RF, either 3.3V or 5V
# 40	VIN_3V3	Power	Digital power supply 3.3V

4.3 Recommended PCB layout

The following footprint is recommended for systems which will be reflow-soldering the M519 as a module.

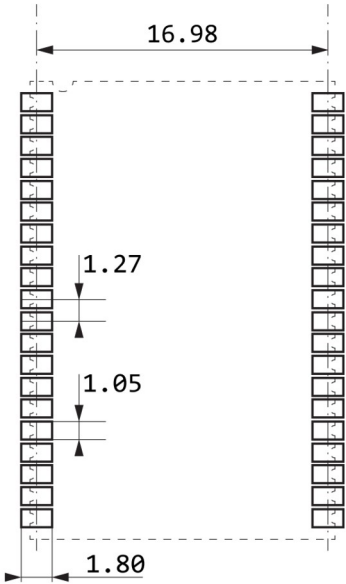

RECOMMENDED PCB LAYOUT

Figure 4: Recommended PCB layout to place the module

4.4 Tape and reel packaging

The M519 is delivered in Tape and Reel.

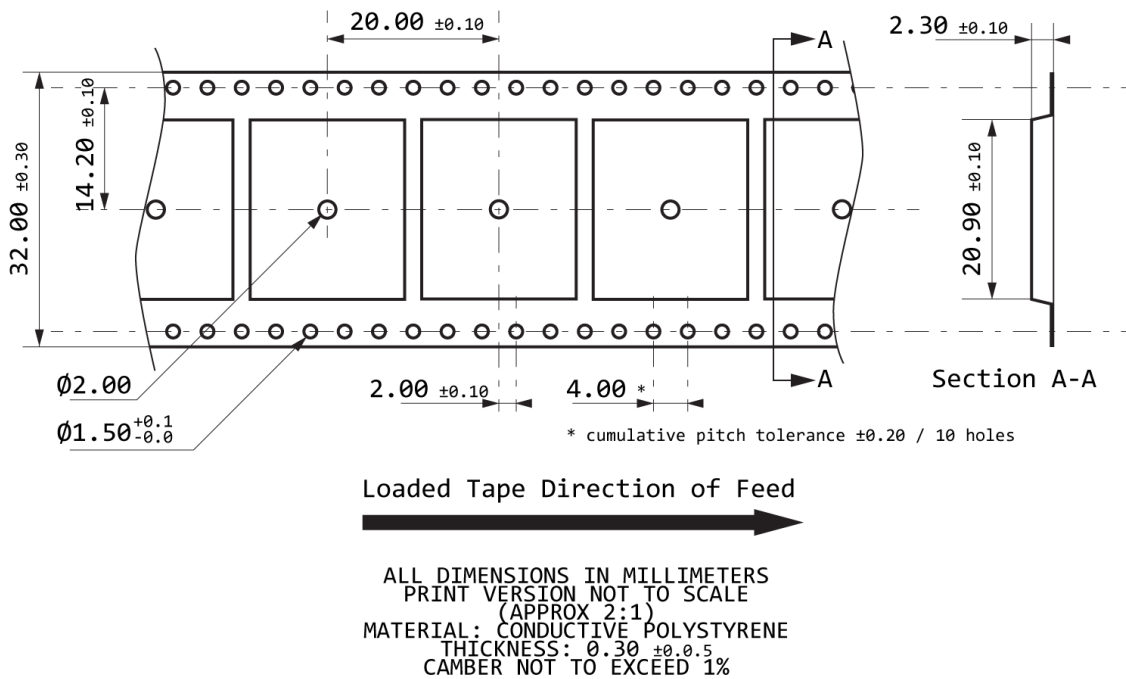

Figure 5: Tape specification

5 Electrical specification

5.1 Limiting values

Stresses beyond those listed under 'Limiting values' may cause permanent damage to the device. This is a stress rating only and functional operation of the device at these conditions is not implied. Exposure to absolute maximum rating conditions for extended periods may affect device reliability.

Symbol	Parameter	Conditions	Min	Max	Unit
VIN_3V3 _{ABS}	Supply voltage on pin VIN_3V3		0	3.6	V
VBUS _{ABS}	Supply voltage on pin VBUS		0	5.5	V
VIN_RF _{ABS}	Supply voltage on pin VIN_RF		0	4.8	V
V _{ANA}	Voltage on any analog pin		0	VIN_3V3	V
V _{DIG}	Voltage on any digital pin		0	VIN_3V3 + 0.2	V
V _{ESD}	Electrostatic discharge voltage		-500	500	V
T _{JUNCTION}	Junction temperature		—	+120	°C
T _{STORAGE}	Storage temperature	No voltage applied	-20	+70	°C

5.2 Power

5.2.1 Power supply voltage

5.2.1.1 USB operation

Symbol	Parameter	Min	Typical	Max	Unit
VBUS	Digital supply voltage, USB	4.5	5.0	5.2	V
VIN_RF _{VBUS}	RF supply voltage, USB	3.0	VBUS – 0,5	4.8	V

Pin # 40 VIN_3V3 shall be left unconnected for USB operation.

5.2.1.2 Serial operation

Symbol	Parameter	Min	Typical	Max	Unit
VIN_3V3	Digital supply voltage, Serial	3.0	3.3	3.6	V
VIN_RF _{3V3}	RF supply voltage, Serial	3.0	VIN_3V3	4.8	V

Pin # 38 VBUS shall be left unconnected for Serial operation.

5.2.2 Current consumption

5.2.2.1 USB operation

Symbol	Parameter / Conditions	Min	Typical	Max	Unit
I _{VBUS,UNLOADED}	Digital power supply, USB, no power drain on VOUT, no smart card	—	25	35	mA
I _{VBUS,LOADED}	Digital power supply, USB, 100mA power drain on VOUT, smart card VCC active	—	230	240 ^B	mA
I _{VIN_RF,USB}	RF power supply, USB	—	110	300 ^{A,B}	mA

A Max RF power may be restricted by configuration, to reduce the total power requirement (at the price of a shorter operating range).

B The USB 2.0 specification does not allow a device to drain more than 500mA. Keep this limit in consideration when designing the device: limit the RF power (by configuration, see point A, or by choosing a small antenna), accept only

low power smart cards (class C / 1.8V, less than 50mA, and not class B / 3.3V nor class A / 5V), or configure the M519 so that the contactless slot is disabled when a contact card is inserted.

5.2.2.2 Serial operation

Symbol	Parameter / Conditions	Min	Typical	Peak	Unit
$I_{3V3,UNLOADED}$	Digital power supply, Serial, no power drain on VOUT, no smart card	—	35	50	mA
$I_{3V3,LOADED}$	Digital power supply, Serial, 100mA power drain on VOUT, smart card VCC active	—	240	260	mA
$I_{VIN,RF,3V3}$	RF power supply, Serial	—	115	310*	mA

* Max RF power may be restricted by configuration, to reduce the total power requirement (at the price of a shorter operating range).

5.3 VOUT pin

Symbol	Parameter	Min	Typical	Max	Unit
VOUT	Peripheral(s) power supply voltage	3.0	3.3	3.6	V
I_{VOUT}	Peripheral(s) power supply current	—	—	100	mA

5.4 SC_VCC pin

Symbol	Parameter	Min	Typical	Max	Unit
SC_VCC	Smart card power supply voltage	3.0	3.3	3.6	V
$I_{SC,VCC}$	Smart card power supply current	—	—	100	mA

5.5 /RESET, /SUSPEND, /SC_IRQ pins

These digital input pins have permanent internal pull-up resistors.

Symbol	Parameter	Min	Typical	Max	Unit
V_{IL}	Low level input voltage	—	—	1.0	V
V_{IH}	High level input voltage	2.4	—	—	V
I_{IL}	Low level input leakage current	55	80	165	μA
I_{IH}	High level input leakage current	—	± 0.01	± 1	μA

5.6 /FLASH, MODE0, MODE1 pins

These digital input pins have internal pull-up resistors that are enabled at boot time, but disabled once the firmware is running.

Symbol	Parameter	Min	Typical	Max	Unit
V_{IL}	Low level input voltage	—	—	1.0	V
V_{IH}	High level input voltage	2.4	—	—	V
I_{IL}	Low level input leakage current	55	0.1	165	μA
I_{IH}	High level input leakage current	—	± 0.01	± 1	μA

5.7 RX, PER_RX pins

These digital input pins have no internal pull-up resistors.

Symbol	Parameter	Min	Typical	Max	Unit
V_{IL}	Low level input voltage	—	—	1.0	V
V_{IH}	High level input voltage	2.4	—	—	V
I_i	Input leakage current	—	± 0.01	± 1	μA

5.8 TX, PER_TX, /PER_EN, /WAKEUP, SC_RST, SC_CLK, I2C_SCL pins

These are digital output pins.

Symbol	Parameter	Conditions	Min	Typical	Max	Unit
V_{OL}	Low level output voltage	$I_{OL}=1mA$	0	0.3	0.6	V
V_{OH}	High level output voltage	$I_{OH}=1mA$	2.7	3.0	3.3	V
I_o	Output current		—	—	± 2	mA
SR	Up or down transition time		—	—	0.04	μs

5.9 SC_IO, /PER_CS, PER_CLK, I2C_SDA pins

These pins are digital input and output; when used as input, they have no internal pull-up resistors.

5.9.1 As input

Symbol	Parameter	Min	Typical	Max	Unit
V_{IL}	Low level input voltage	—	—	1.0	V
V_{IH}	High level input voltage	2.4	—	—	V
I_i	Input leakage current	—	± 0.01	± 1	μA

5.9.2 As output

Symbol	Parameter	Conditions	Min	Typical	Max	Unit
V_{OL}	Low level output voltage	$I_{OL}=1mA$	0	—	0.6	V
V_{OH}	High level output voltage	$I_{OH}=1mA$	3.5	3.6	VCC	V
I_o	Output current		—	—	± 2	mA
SR	Up or down transition time		—	—	0.04	μs

5.10 GPIO1, GPIO2, GPIO3, GPIO4, GPIO5 pins

These pins are digital input and output; when used as input, they do have internal pull-up resistors.

5.10.1 As input

Symbol	Parameter	Min	Typical	Max	Unit
V_{IL}	Low level input voltage	—	—	1.0	V
V_{IH}	High level input voltage	2.4	—	—	V
I_{IL}	Low level input leakage current	55	80	165	μA
I_{IH}	High level input leakage current	—	± 0.01	± 1	μA

5.10.2 As output

Symbol	Parameter	Conditions	Min	Typical	Max	Unit
V_{OL}	Low level output voltage	$I_{OL}=1mA$	0	—	0.6	V
V_{OH}	High level output voltage	$I_{OH}=1mA$	2.7	3.0	3.3	V
I_o	Output current		—	—	± 2	mA
SR	Up or down transition time		—	—	0.04	μs

6 Application information

6.1 Operating modes, profiles and protocols

The M519 is a versatile module, based on the SpringCard SpringCore firmware, that supports many operating modes. Every operating mode is associated to one or more USB profile and Serial communication protocol. The choice of the operating mode and of the host interface is done upon reset (see § 6.3).

The paragraphs below summarizes the options and explains the basics; for a complete reference, please read the documentation of the SpringCore firmware:

https://docs.springcard.com/books/SpringCore/Introduction/Operating_Modes

6.1.1 PC/SC Coupler mode

In this mode, the M519 is a complete smart card coupler: it can perform any transaction with a smart card, under full control of an application running in the host computer.

The smart card may be either contact or contactless (NFC/RFID) depending on only on its hardware interface, but operated the same way seen from the software interface.

As a PC/SC device, the M519 is typically associated to a PC/SC driver and is supported by the computer's PC/SC stack.

The PC/SC Coupler mode is selected by writing $_H02$ into configuration register $_H02C0$, or by driving $MODE0=HIGH$, $MODE1=LOW$ on reset.

6.1.1.1 USB

When the PC/SC Coupler mode is selected and the host interface is USB, the M519 is a compound device that exposes both the CCID profile and the SpringCore Direct profile (*more on the Direct profile in § 6.1.3*).

The CCID profile of the M519 is fully supported by the open-source CCID driver available on Linux together with the PC/SC-Lite stack, and by the CCID driver and PC/SC stack

provided by Apple for macOS. For Microsoft Windows, SpringCard driver SD16055 shall be used³.

6.1.1.2 Serial

When the PC/SC Coupler mode is selected and the host interface is Serial, the M519 uses the CCID over Serial protocol.

See Application Note PNA23174 “Using the M519 in PC/SC Coupler mode over a Serial interface” for reference.

6.1.2 Smart Reader mode

In this mode, the M519 is an autonomous or NFC/RFID reader.

It automatically grabs a token from a contactless cards, NFC tags or RFID labels, before transmitting it to the host. This simplifies the development of the host application, because the M519 runs the transaction with the card, tag or label in a standalone-reader approach.

This also makes it possible to use a fast anticollision/inventory scheme, overriding the bottleneck introduced by a slow computer-based transaction or a too complex driver stack.

The Smart Reader mode is selected by writing $_H03$ into configuration register $_H02C0$, or by driving $MODE0=LOW$, $MODE1=HIGH$ on reset.

6.1.2.1 USB

When the Smart Reader mode is selected and the host interface is USB, the M519 is a compound device that exposes both the HID keyboard profile and the SpringCore Direct profile (*more on the Direct profile in § 6.1.3*).

Thanks to the standard HID keyboard profile, the M519 is automatically recognized as a keyboard by all the major operating systems that support USB (Windows, macOS, Linux, Android, iOS...), and the data collected from NFC/RFID tags are automatically received as key-strokes in the active application. SpringCard calls this feature “RFID Scanner”.

³ Microsoft also provides a CCID driver that works fine with the M519, but unfortunately this driver is single-slot only. Using SpringCard driver instead adds multi-slot support and simplifies the development.

For correct operation, the user must configure the M519 with the same keyboard layout as the host system.

6.1.2.2 Serial

When the Smart Reader mode is selected and the host interface is Serial, the M519 sends the data collected from NFC/RFID tags over its serial line, using the protocol selected in configuration register $H02A0$.

- **\$SCRDR protocol** (default): data come as ASCII strings, starting with constant value "\$SCRDR".

Format specification:

```
$SCRDR;<Interface>;<Protocol>;<Template>;<RSSI>;<TagId>;<Move>;<TagData>;<TagDe tails>*<Checksum><CR><LF>
```

Example:

```
$SCRDR;13.56;NFC-A;1;;047DAE02C84080;;00047DAE02C84080;*47<CR><LF>
```

- **MK1 protocol**: this is a legacy protocol, taken from earlier SpringCard devices, that provides only the TagId. The \$SCRDR protocol shall be preferred.

Example:

```
+047DAE02C84080<CR><LF>
```

- **JSON protocol**: data is encapsulated in a JSON object.

Example:

```
{
  "Interface": "13.56",
  "Protocol": "NFC-A",
  "Template": 1,
  "TagId": "047DAE02C84080",
  "TagData": "00047DAE02C84080",
  "Uptime": "699:16.850"
}
```

- **TLV protocol**: data object uses ASN.1 binary encoding rule.

Example:

```
B0 0E C1 04 00 03 01 01 C2 07 04 7D AE 02 C8 40 80
```

6.1.3 Direct protocol and fail-safe mode

SpringCore Direct is a proprietary protocol for new SpringCard devices that allows to flash, configure and use a device with more flexibility and faster than other protocols.

Most SpringCard software, like the SpringCore Tools and SpringCard Companion, rely on the SpringCore Direct protocol to access the devices in a seamless way, whatever their host interface and operating modes are. This protocol also allows an application to have full control over the reader, for advanced Smart Reader operation.

In the M519, the Direct protocol is associated to a fail-safe mode: the device bypass all configuration settings that may disable an interface or prevent communication, and disables most power sinks, to help debugging or fine-tuning the system.

The SpringCore Direct protocol and the fail-safe mode are selected by writing `0x00` into configuration register `0x02C0`, or by driving `MODE0=LOW`, `MODE1=LOW` on reset.

6.1.4 SpringProx Legacy

SpringProx Legacy is the proprietary protocol and mode of operation introduced in the 2000's with the first generation of SpringCard devices. PC/SC Coupler mode and the CCID protocol shall be preferred when designing a new system.

It must be understood by the developer/implementer that the M519 is not a drop-in replacement for earlier K531, K632, K663, CSB4. The high-level behaviour is the same, but low-level control of the RF interface has to be rewritten. Anyway, in most situations, the migration process is straightforward provided that you have access to the source code of the Legacy application.

The SpringProx Legacy mode and protocol are selected by writing `0x01` into configuration register `0x02C0`.

6.1.4.1 USB

When the SpringProx Legacy is selected and the host interface is USB, the M519 uses the USB CDC ACM profile (communication device class, abstract control model). It is automatically recognized as a (virtual) communication port by all the major desktop operating systems (Windows, macOS, Linux...). The M519 accepts SpringProx Binary

and ASCII messages (not OSI3964) and it is possible to use the `springprox.dll` over this (virtual) communication port without a change.

6.1.4.2 Serial

When the SpringProx Legacy is selected and the host interface is Serial, the M519 accepts SpringProx Binary and ASCII messages (not OSI3964) and it is possible to use the `springprox.dll` without a change.

6.2 Bootloader, firmware upgrade

The M519 features a bootloader that allows to change its firmware. There are two ways to perform the upgrade: in-the-field, over a live system (Live upgrade) or after having explicitly activated the bootloader.

6.2.1 Live upgrade

The typical firmware upgrade procedure is:

- A new firmware is transmitted using the Direct protocol while the M519 is operating “normally” (this new firmware is written in a temporary storage area),
- When the M519 resets, its bootloader copies the new firmware from the storage area to the ROM of the microcontroller,
- The M519 resets again, running its new firmware.

When the Live upgrade procedure is used, the user application does not need to activate the bootloader explicitly, nor to communicate with the bootloader.

When the host uses the USB interface, Live upgrade is always possible because the Direct protocol is always available, at least as a secondary profile (compound device).

To perform the upgrade over USB, use either:

- SpringCoreFlash, a command line tool (member of the SpringCore Tools suite) that is easy to deploy and run unattended

<https://www.springcard.com/fr/download/find/file/sq20029>

- SpringCard Companion, a web application + local service, for a more user-friendly experience.

<https://companion.springcard.com>

6.2.2 Bootloader upgrade

Live upgrade is not possible when the host uses the Serial interface and the configuration does not enforce Direct protocol, fail-safe mode.

In this case, the host must explicitly restart the M519 in bootloader mode, and write the new firmware directly in the ROM of the microcontroller through the bootloader.

The bootloader is activated by driving `/FLASH=LOW` on reset or by sending command `flash<CR><LF>` through the shell (§ 6.4).

The bootloader uses a simplified implementation of the Direct protocol, where only the DFU class (Device Firmware Upgrade) is available:

https://docs.springcard.com/books/SpringCore/Host_Protocols/Direct_Protocol/DFU_class/index

Once the bootloader has been activated, you may also use SpringCoreFlash to perform the upgrade over either the USB or the Serial interface.

6.3 Reset configuration and MODE0, MODE1 pins

When the M519 is powered-up or its `/RESET` pin is risen (Low to High transition), the module resets and probes `VIN3_V3`, `VBUS`, `/FLASH`, `MODE0` and `MODE1` to read its reset configuration.

The reset configuration defines:

1. whether the host interface is the serial line or the USB bus,

VBUS	VIN_3V3	Host interface
5V	—	USB
unconnected	3.3V	Serial

Do not connect anything to VBUS unless you want to activate USB.

2. whether the M519 activates its main firmware or stays in bootloader mode,

/FLASH	Firmware activation
LOW	M519 runs its bootloader
HIGH	M519 runs its firmware

You may leave the /FLASH pin unconnected if your application does not need to activate the bootloader.

3. when the main firmware is activated, which operating mode shall be selected.

MODE0	MODE1	Operating mode
HIGH	HIGH	As set in non-volatile memory (configuration register μ 02C0)
HIGH	LOW	PC/SC Coupler
LOW	HIGH	RFID Scanner (USB) or Smart Reader (Serial)
LOW	LOW	SpringCore Direct, fail-safe mode

You may leave the MODE0 and MODE1 pins unconnected if your application does not need to change the mode.

The table below summarizes all the supported reset configurations and the associated USB profiles or Serial protocol:

VBUS	VIN_3V3	/FLASH	MODE0	MODE1	Interface	Operating mode	Profile/Protocol
5V	—	LOW	—	—	USB	Bootloader	Direct (DFU)
5V	—	HIGH	HIGH	HIGH	USB	Set by configuration register $_H02C0$	
5V	—	HIGH	HIGH	LOW	USB	PC/SC Coupler	CCID+Direct
5V	—	HIGH	LOW	HIGH	USB	RFID Scanner	HID keyboard+Direct
5V	—	HIGH	LOW	LOW	USB	Direct, fail-safe	Direct
N/C	3.3V	LOW	—	—	Serial	Bootloader	Direct (DFU)
N/C	3.3V	HIGH	HIGH	HIGH	Serial	Set by configuration register $_H02C0$	
N/C	3.3V	HIGH	HIGH	LOW	Serial	PC/SC Coupler	CCID+Console
N/C	3.3V	HIGH	LOW	HIGH	Serial	Smart Reader	\$SCRDR+Console
N/C	3.3V	HIGH	LOW	LOW	Serial	Direct, fail-safe	Direct+Console

6.4 Serial shell

The M519 features a “human console” shell, that is available over its Serial interface

- whatever the operating mode,
- whether the host interface is Serial or USB.

The shell is namely used to explore or fine-tune the M519, or debug the system.

The communication parameters are:

- Baudrate: 38400bps,
- Format: 8 data bits, 1 stop bit, no parity, no flow control.

Note that if the shell is always enabled with these parameters when the device resets, it is generally disabled once the host has activated another protocol or changed the communication parameters. Always reset the device before trying to use the shell.

Send `<CR><LF>` to get the prompt of the device, that exposes its version and current operating mode.

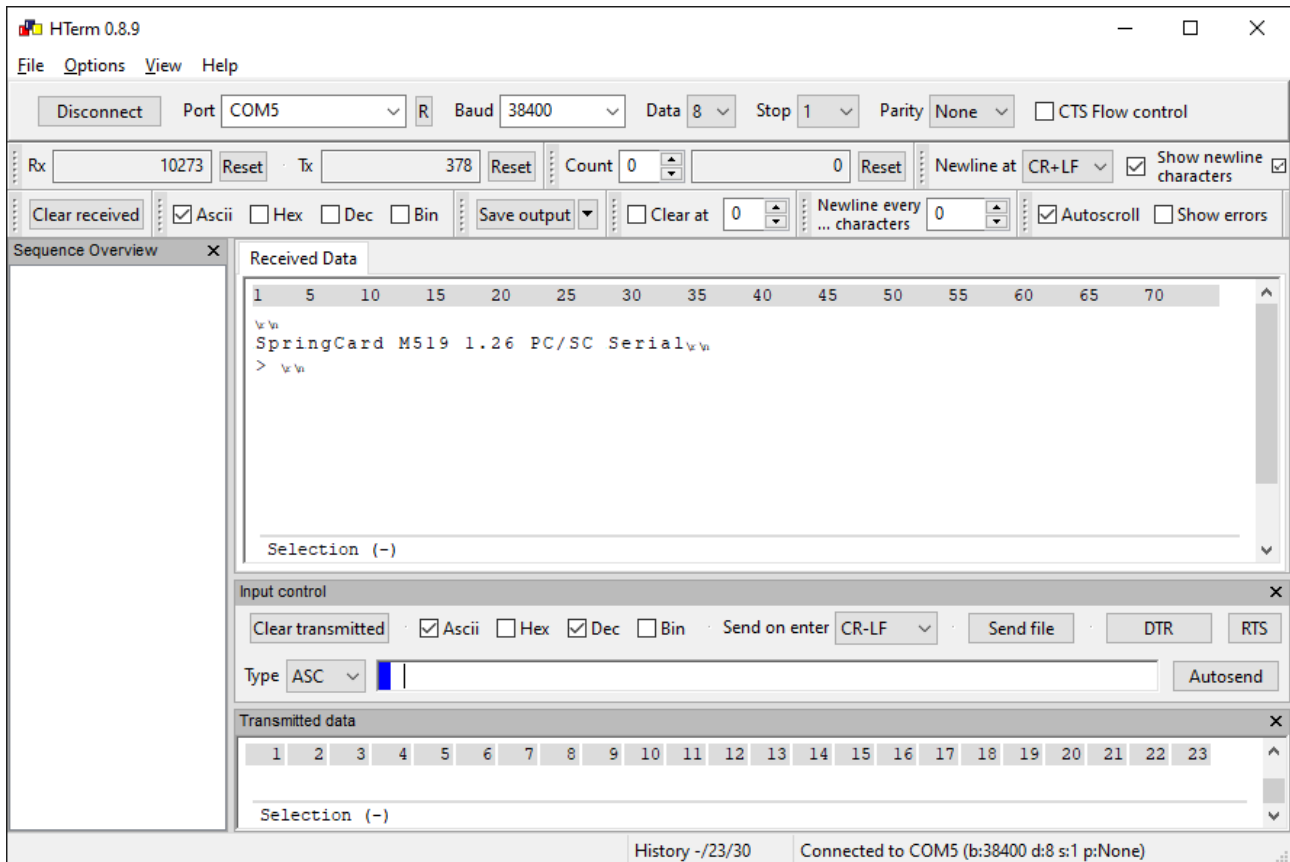

In the snapshot above,

- “v1.26” is the version number of the firmware. Newer firmwares will show another version number,
- “PC/SC” is the operating mode. Other possible values are “Direct”, “SmartReader”, “RFIDScan” and “Legacy”,
- “Serial” is the primary host interface. Other possible value is “USB”.

Enter `help<CR><LF>` to read the list of available commands.

6.5 Configuring the M519

The M519 is highly configurable. You may download a configuration file from SpringCard Companion, or use a configuration file provided by SpringCard or a 3rd party. Configuration files use either the JSON or the CFG format.

The new configuration may be injected into the M519 by the mean of a software provided by SpringCard, by the host application itself, or using a Master Card. When exploring/evaluating the M519, it is also possible to edit the configuration with the shell.

Warning: writing an invalid configuration may disable the host interface(s) and prevent any communication with the device.

6.5.1 SpringCard configuration software

When the host uses the USB interface, in-the-field, Live configuration by SpringCard-provided software is always possible, because the Direct protocol is always available (at least as a secondary profile in the compound device).

To write a new configuration over USB, use either:

- SpringCoreConfig, a command line tool (member of the SpringCore Tools suite) that is easy to deploy and run unattended

<https://www.springcard.com/fr/download/find/file/sq20029>

- SpringCard Companion, a web application + local service, for a more user-friendly experience.

<https://companion.springcard.com>

6.5.2 Configuration through Master Cards

This feature is not yet implemented in the current version of the firmware.

6.5.3 Configuration by shell commands

In the Serial shell (§ 6.4),

- Send command `cfg<CR><LF>` to read the current configuration,
- Send command `cfgXX=YYYY<CR><LF>` to write value `ₕYYYY` in configuration register H02XX,
- Send command `cfgXX=<CR><LF>` to erase configuration register `ₕ02XX` (the default value will apply).

6.5.4 Configuration by the host application

The CONTROL class of the Direct protocol, that is also available through the SCardControl function of the PC/SC Coupler mode, let the host application configure the M519.

For reference, please read:

https://docs.springcard.com/books/SpringCore/Host_Protocols/Direct_Protocol/CONTROL_class/index

7 Integration Guide – Host Interface and power supply

The M519 supports either USB or Serial as host interface.

The USB interface is enabled by powering the module at 5V DC, using the VBUS line coming from the USB host or the USB hub.

If VBUS is not active and the module is powered at 3.3V DC over its VIN_3V3 line, then the Serial interface is enabled.

Warning: for debugging and manufacturing reasons, the Serial interface remains active when the USB interface is enabled, but using both interfaces at the same time is absolutely not supported and is likely to make the M519 reset or behave incorrectly. Leave the Serial interface unconnected when you want to use the M519 as a USB device.

7.1 USB

7.1.1 Overview

The M519 is a USB 2.0 full-speed (12Mbps) device, compliant with USB 3.

USB operation is enabled by connecting the VBUS pin of the module to the 5V supply provided by the bus, and the USB_DP and USB_DM pins to the D+ and D- signals of the bus, respectively. No control signal is required.

The RF supply voltage (VIN_RF pin) is taken from VBUS as well, but, according to the USB specification, VBUS voltage range is 4.75V to 5.25V where VIN_RF must stay under 5.0V (§ 5.2.1.1). Therefore, we add a Schottky diode with a forward voltage drop of 0.5V (B230A or equivalent) in the trace.

The reference schematics next page is based on a USB-C connector, but it is trivial to adapt it to a USB mini-B or micro-B connector.

Warning: designing a PCB that incorporates a USB 2.0 peripheral requires careful consideration of various factors to ensure reliable operation. Please read § 7.1.3 carefully and respect all the constraints and recommendations it contains.

7.1.2 Reference schematics

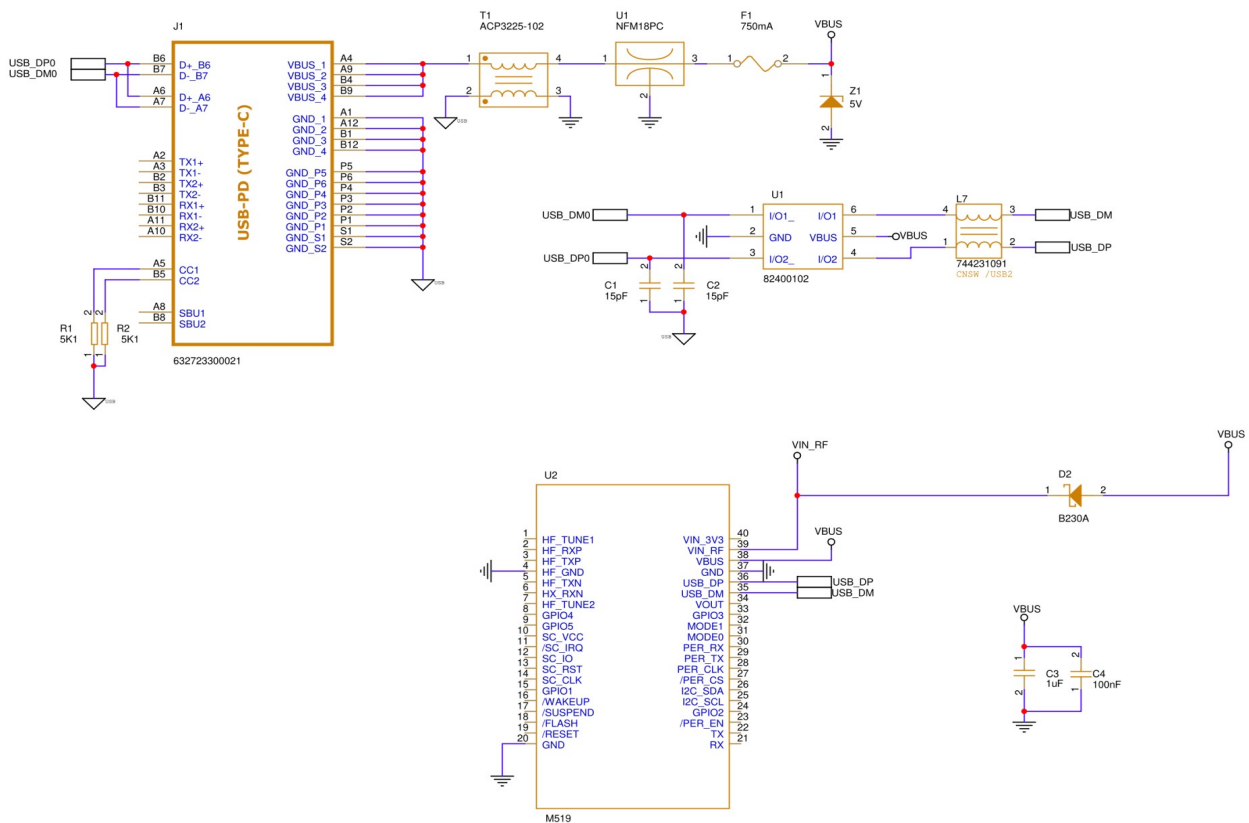

Figure 6: Reference schematics, M519 with USB-C as host interface

7.1.3 Precautions

Designing a PCB to create incorporates a USB peripheral requires careful consideration of various factors to ensure reliable operation.

Differential pair routing:

Maintain the USB differential pairs (D+ and D-) length matched. Mismatches can lead to signal integrity issues. Keep the differential traces close together to maintain the differential impedance. Avoid sharp bends or vias on the differential pairs. If vias are necessary, ensure both lines have a similar number and layout.

Trace length:

Keep USB trace lengths as short as possible. The total length of the USB differential pair traces from the USB connector to the module should be kept under 50mm. Minimize any stubs on the USB data lines. Stubs can introduce reflections and degrade signal integrity.

Separation from noisy traces:

Keep USB traces away from high-speed or noisy traces, such as clock lines, to avoid cross-talk or interference. Separate USB traces from switching power supplies or other potentially noisy components.

Decoupling and filtering:

Place the ESD suppressor (U1, part number Wurth Elektronik 82400102), the common-mode chokes (L7, part number Wurth Elektronik 744231091 and T1, part number TDK ACP3225) and the EMI filter (U1, part number Murata NFM18PC) near the USB connector to suppress noise and protect against electrostatic discharges.

Place decoupling capacitors C3 and C4 close to the power pins of the module.

Ground plane:

A solid, continuous ground plane beneath the USB traces can help improve signal integrity. Ensure a good connection between the ground of the USB connector and the ground plane.

Connector quality:

Use high-quality USB connectors that are durable and have good shielding. Ensure the mechanical stability of the USB connector. It should be securely mounted to the PCB, with extra mechanical support if the application expects frequent plug/unplug cycles.

Shielding:

Do not connect the shield of the USB connector to the ground directly but by the mean of the common mode filter (T1, part number TDK ACP3225).

Cable, hub or host:

The quality of the USB cable used, as well as its length, can influence performance. Always fully unroll the USB cable. A cable that remains coiled introduces parasitic inductance and exposes the USB interface to the magnetic field generated by the antenna.

The stability of the voltage provided by either the hub or the host on VBUS can have a dramatic impact on the RF performances and even on the stability of the USB communication. Make sure that all requirements of the USB specification are met at the M519's pins, whatever the run-level or the power supply of the host is.

Testing, validation and qualification:

Once the PCB is fabricated, it's crucial to test USB functionality under various conditions (e.g., different cable lengths, with various hosts) to validate the design.

EMC product qualification (necessary for CE, FCC marking and other) should be conducted with the final product (including the cable that would be used in the field). Exchanges must be going on both on the USB interface and on the RF interface simultaneously during the measures.

SpringCard has a strong experience in designing USB NFC/RFID HF devices. Don't hesitate to contact us should you need the assistance of an expert in designing or qualifying your own product.

7.1.4 USB IDs, profile and descriptors

The USB profile —and therefore the Product ID and the descriptors announced by the device— depends on the operating mode as selected by configuration register $_H02C0$ or by the MODE0/MODE1 pins.

Operating mode	Vendor ID	Product ID	Profile
SpringCore Direct ^A	$_H1C34$	$_H6210$	WinUSB
SpringProx Legacy ^B	$_H1C34$	$_H6211$	Compound, CDC-ACM + WinUSB
PC/SC Coupler ^C	$_H1C34$	$_H6212$	Compound, CCID + WinUSB
RFID Scanner ^D	$_H1C34$	$_H6213$	Compound, HID keyboard + WinUSB
Smart Reader ^E	$_H1C34$	$_H6214$	Compound, CDC-ACM + WinUSB
PC/SC Coupler, no Direct interface ^F	$_H1C34$	$_H621A$	CCID

A: selected by MODE0,MODE1=0,0 or MODE0,MODE1=1,1 and $_H02C0=_H00$ and $_H02C1.bit3=_B0$

B: selected by MODE0,MODE1=1,1 and $_H02C0=_H01$ and $_H02C1.bit3=_B0$

C: selected by MODE0,MODE1=1,0 or MODE0,MODE1=1,1 and $_H02C0=_H02$ and $_H02C1.bit3=_B0$

D: selected by MODE0,MODE1=0,1 or MODE0,MODE1=1,1 and $_H02C0=_H03$ and $_H02C1.bit3=_B0$

E: selected by MODE0,MODE1=1,1 and $_H02C0=_H04$ and $_H02C1.bit3=_B0$

F: selected by MODE0,MODE1=1,0 or MODE0,MODE1=1,1 and $_H02C0=_H02$ and $_H02C1.bit3=_B1$

7.2 Serial

7.2.1 Overview

The serial interface of the M519 is enabled by leaving VBUS unconnected, and by powering the module by the mean of a unique 3.3V supply over both VIN_3V3 and VIN_RF.

Asynchronous serial communication takes place over the UART of the module, on pins RX (# 21, host to module) and TX (# 22, module to host). The /SUSPEND control signal and the /WAKEUP signal for handshaking may be used, but could definitively be left unconnected in most situations.

Warning: the RX and TX pins operate at 0/3.3V. Do not connect them directly to an RS-232 cable. Take appropriate precautions when using the M519 with a 0/5V host.

7.2.2 Reference schematics

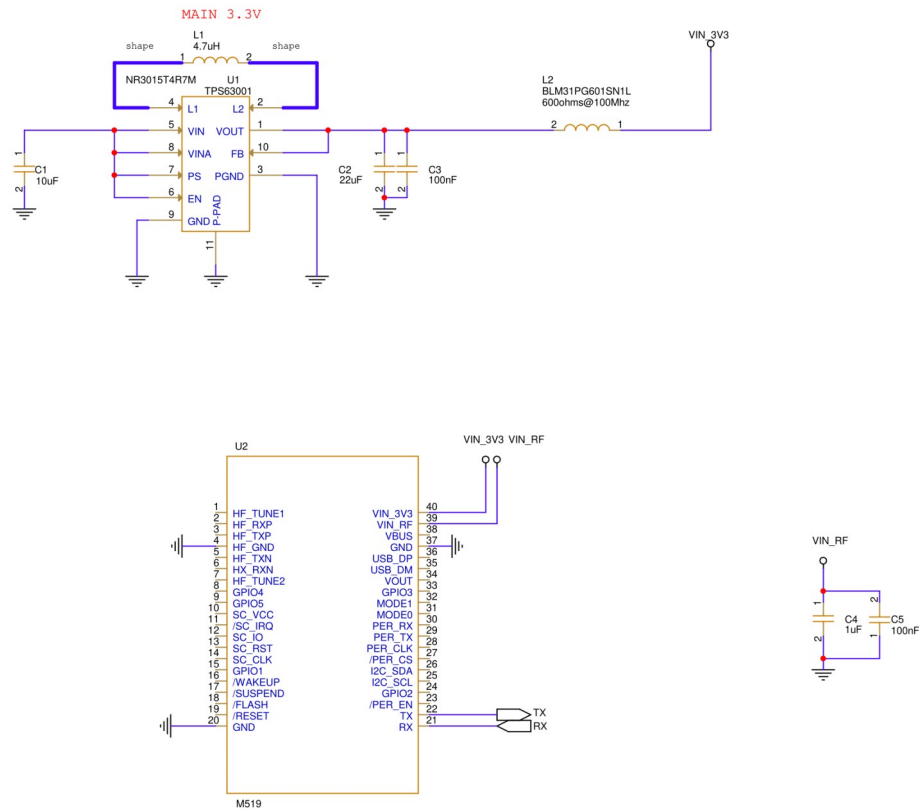

Figure 7: Reference schematics, M519 with a serial host interface

7.2.3 Validation the implementation

See § 6.4 .

8 Integration Guide – RF antenna

“Long range” or *far field* radio technologies like Bluetooth, WiFi or RFID UHF, where only the electric field (E) is involved, may work with miniature antennas that may even be embedded in small form-factor modules.

On the other hand, NFC/RFID HF is a *near field* radio technology where only the magnetic field (B) is involved and the card/tag uses power harvesting, which requires a (rather) high field strength. The antenna is an inductive coil, that must be carefully designed to reach the expected operating range in the target environment and with the target cards or tags. Its antenna can't be miniaturized too much, because the typical operating distance (i.e. the distance where the field is strong enough to remotely power the card/tag) is in the same order as its diameter or diagonal. Therefore, the M519 must be associated to an external antenna, specifically designed with all the constraints of the application in mind.

It is impossible to explain all the design considerations in a short Integration Guide. This chapter will provide the reference schematics of a typical antenna, and the PCB layout and BOM of three antennas that are likely to cover most use cases.

SpringCard has a strong experience in designing NFC/RFID HF antennas. Don't hesitate to contact us should you need the assistance of an expert in designing or qualifying your own product. Integrators who are looking for a ready-to-use 'module on antenna' solution are likely to consider the M519-SUV instead of the M519 bare module.

8.1 Static matching circuit

8.1.1 Principle

The M519 needs to be connected to its antenna through an impedance matching circuit (T-filter). The values of the parallel capacitors should be chosen based on the antenna's inductance to make the resonance frequency as close as possible to 13.56MHz. The series capacitors then ensure a real impedance (purely resistive) at this frequency.

It is crucial to adjust the values of the tuning circuit to the exact characteristics of the antenna, which must be measured using a VNA (Vector Network Analyzer) for this

purpose. Simulation alone is not sufficient because a PCB introduces resistances and parasitic capacitors that cannot be predicted with sufficient accuracy. Developing such a system, therefore, requires a certain level of expertise and a good understanding of Nyquist diagrams.

8.1.2 Reference schematics

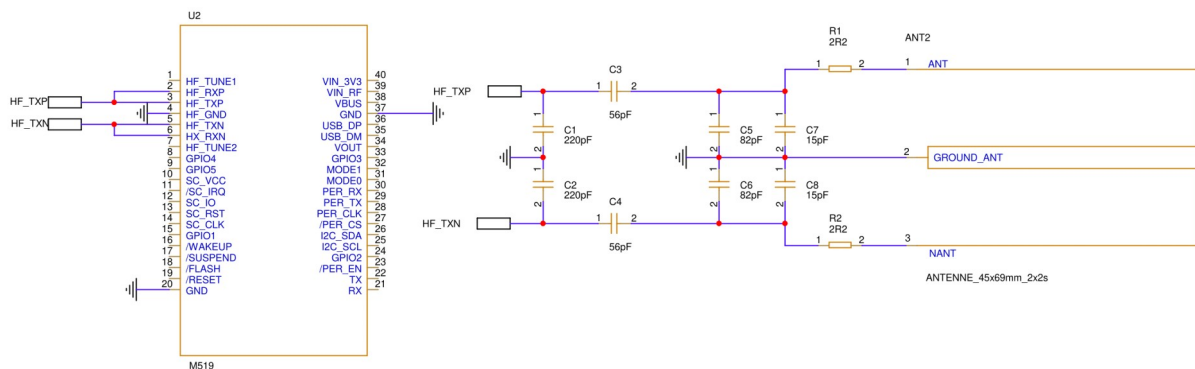

Figure 8: Reference schematics, matching circuit with fixed capacitors

8.2 “Auto-tune” matching circuit

8.2.1 Principle

Some electromagnetic environments, especially the presence of metal near the antenna, can have a significant impact on tuning. There are, in fact, two cumulative effects: a modification of the effective inductance of the antenna and an additional parasitic parallel capacitance between the signal and ground.

The M519 can control a variable tuning circuit that can, to some extent, compensate for the mismatch introduced by the environment. The HF_TUNE_1 signal is used to adjust the series capacitance, and the HF_TUNE_2 signal adjusts the parallel capacitance. When

the auto-tune algorithm is activated, the M519 continuously adjusts the values of these two capacitors.

However, it's essential to remember that the role of this system is to optimize the characteristics of a well-tuned antenna in an environment that degrades its performance. It won't be able to deliver good performance with a poorly tuned antenna.

To be completed. The corresponding feature is not yet implemented in the current version of the firmware.

8.2.2 Reference schematics

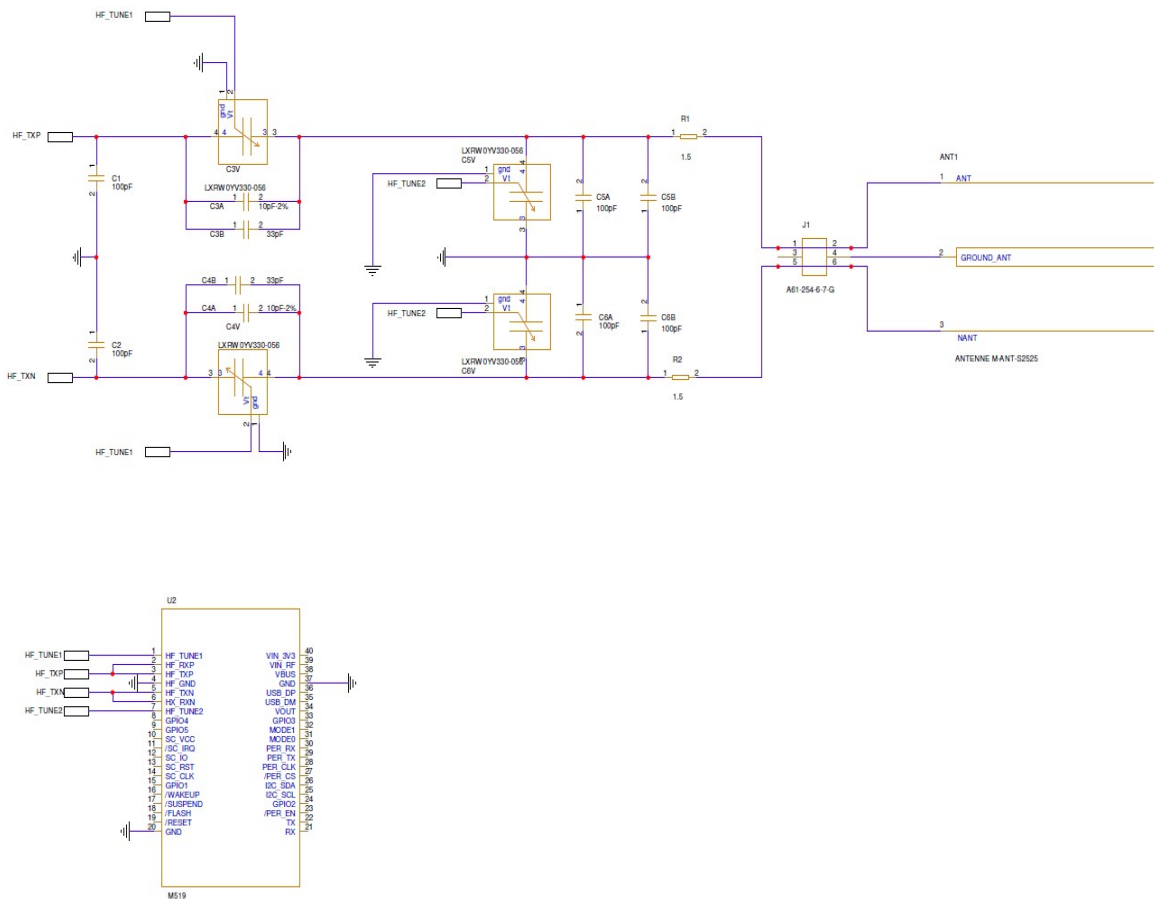

Figure 9: Reference schematics, matching circuit with voltage-driven adjustable capacitors

8.3 Reference PCB layouts and BOMs

SpringCard reference antennas are based on the static matching circuit. The Gerber are reproduced in the following pages for information (images show the layers seen from above). Don't hesitate to contact SpringCard Support to get the actual Gerber files if you want to copy/paste the layouts in your own product.

PCB specifications for the antennas are: Class 4, FR4-based, 4 layers with a total thickness of 1.6mm, copper thickness of 35µm.

The suggested BOMs (bill of materials) provide the nominal values of the components. If you are designing a product that utilizes the "auto-tune" function of the M519, adjust the values of both fixed and variable capacitors so that the nominal capacitance falls in the middle of the range of variation.

8.3.1 69x45mm balanced antenna

This antenna is the foundation of the M519-SUV product, and available as ANT-S6945 in the M519-SRK.

8.3.1.1 Layout

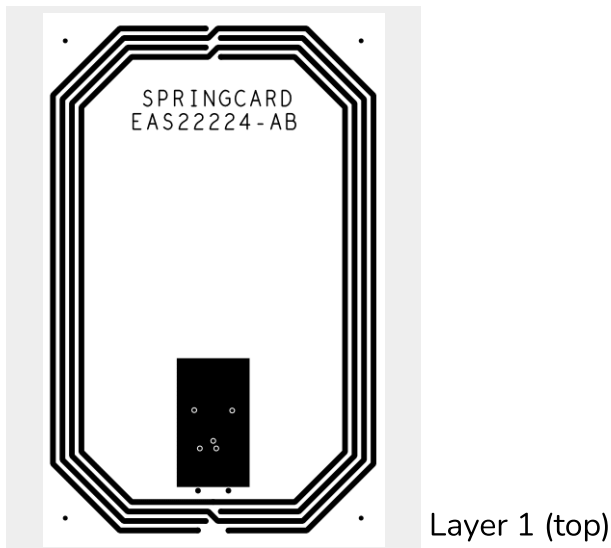

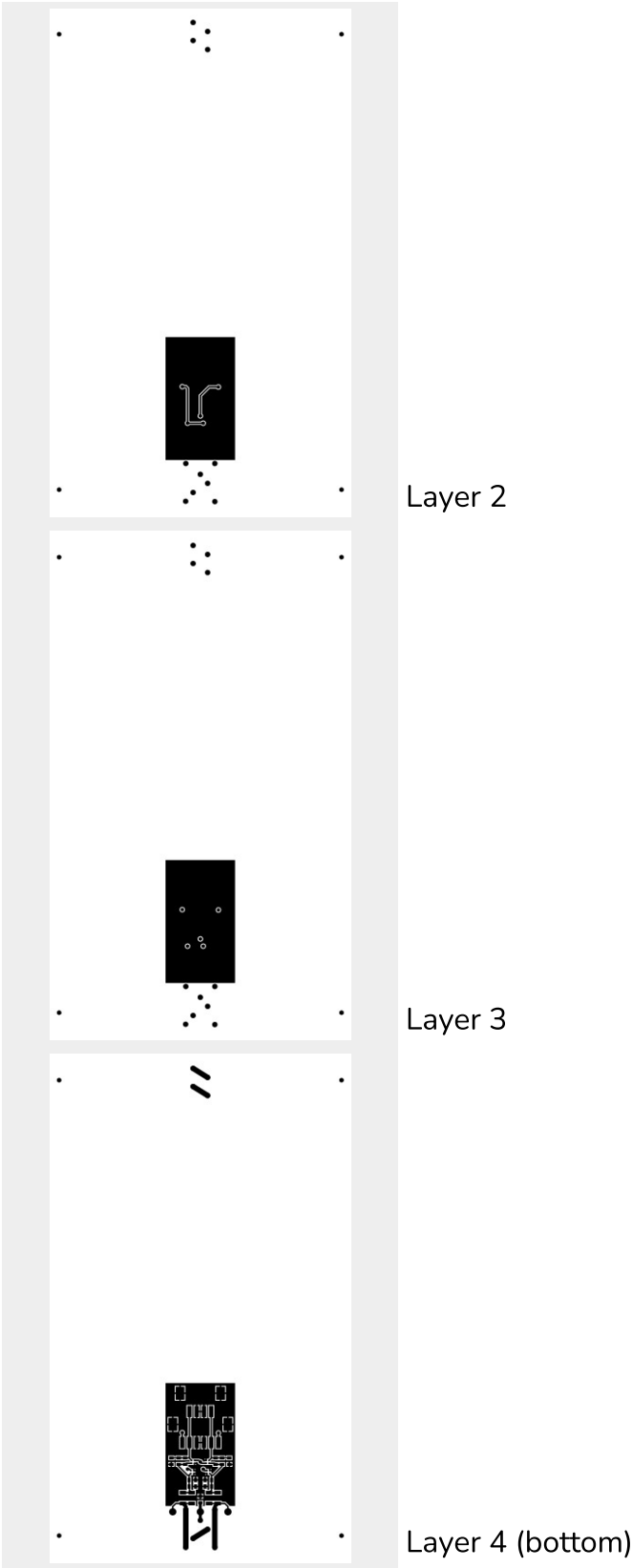

8.3.1.2 BOM

Part	Value	Tolerance	Remark
R1, R2	1.5Ω	±2%	
C1, C2	100pF	±2%	
C3, C4	33pF	±2%	
C5, C6	100pF	±2%	

8.3.2 25x25mm balanced antenna

This antenna is available as ANT-S2525 in the M519-SRK.

8.3.2.1 Layout

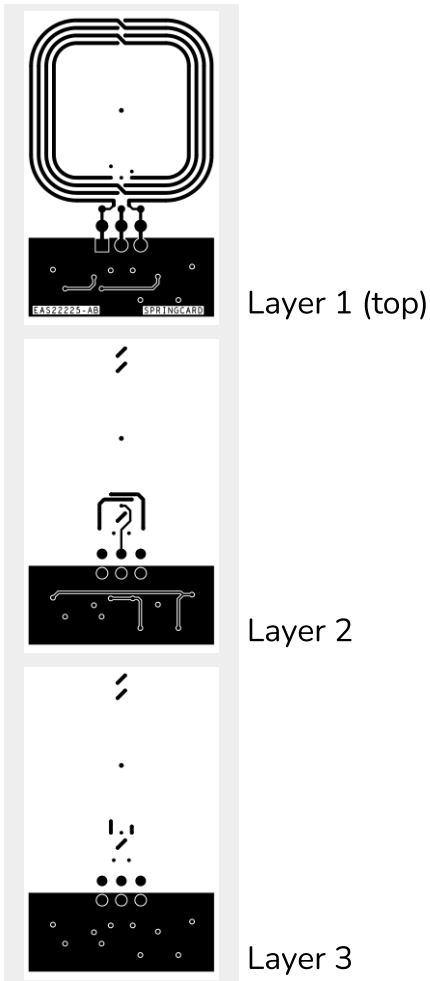

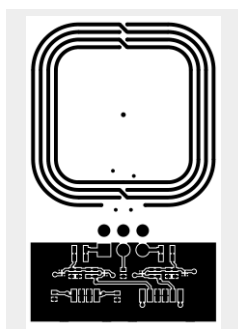

Layer 4 (bottom)

8.3.2.2 BOM

Part	Value	Tolerance	Remark
R1, R2	2.2Ω	±2%	
C1, C2	100pF	±2%	
C3, C4	27pF	±2%	
C5, C6	89pF	±2%	Use 56pF + 33pF

8.3.3 80x80mm balanced antenna

This antenna is available as ANT-S8080 in the M519-SRK.

8.3.3.1 Layout

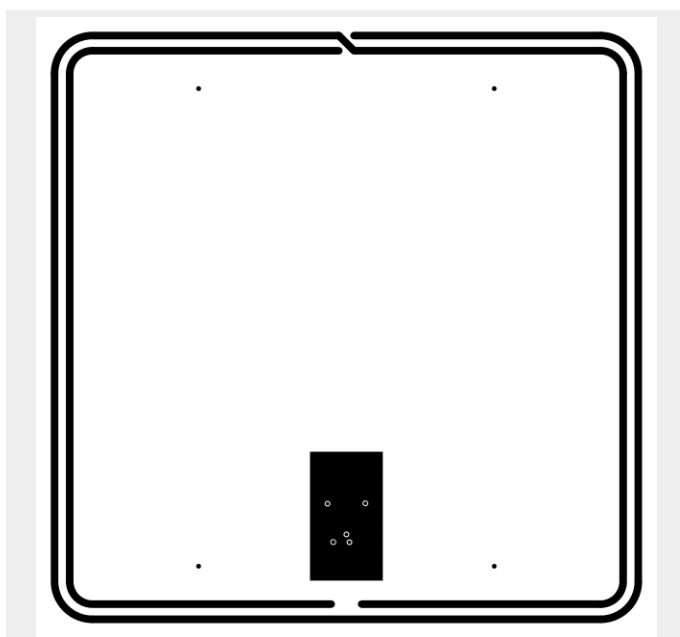

Layer 1 (top)

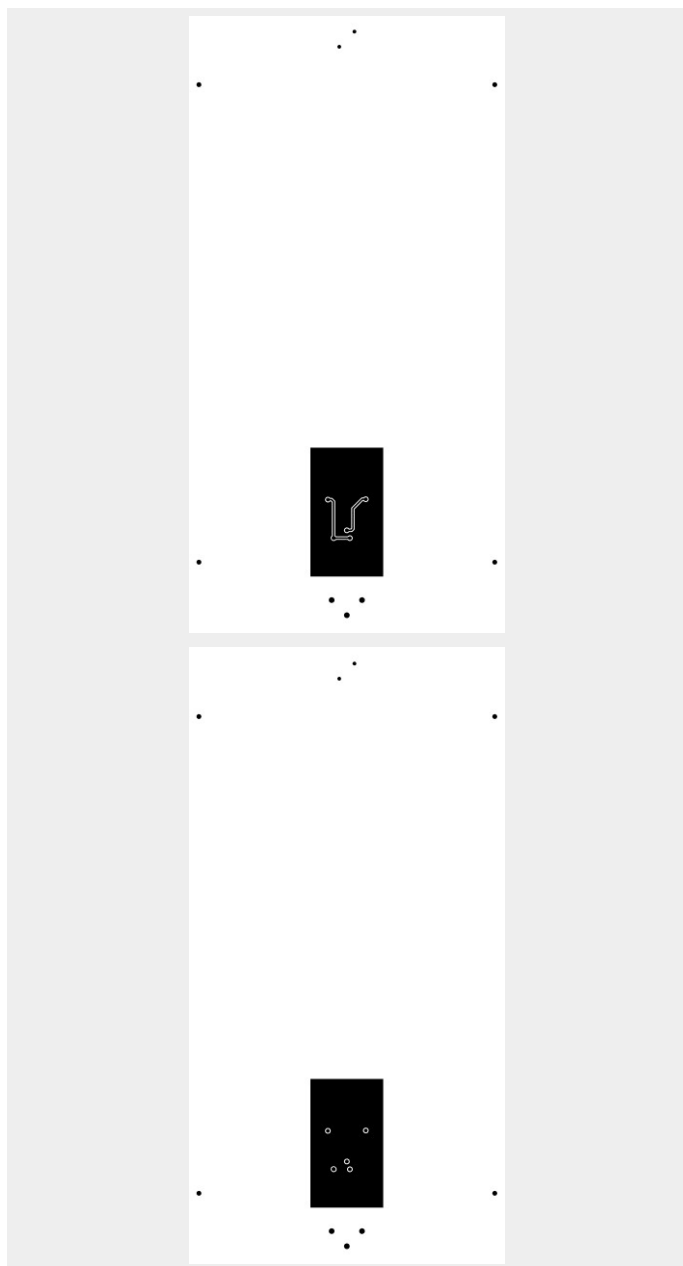

Layer 2

Layer 3

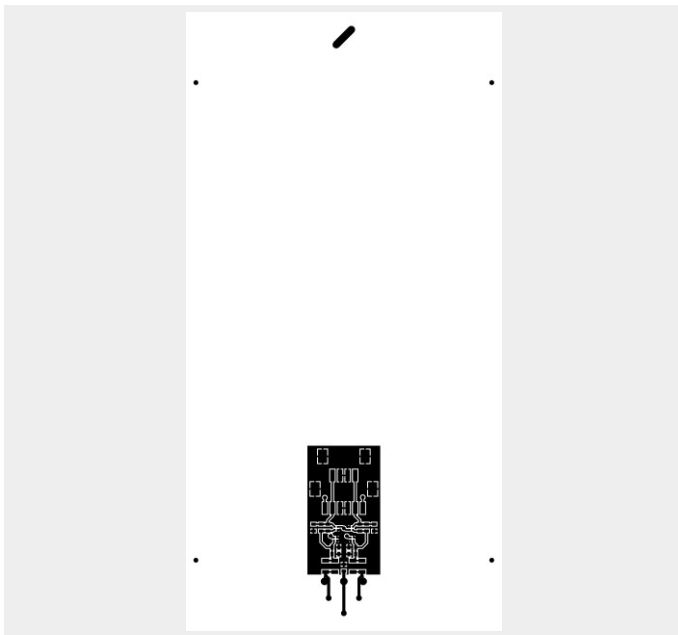

Layer 4 (bottom)

8.3.3.2 BOM

Part	Value	Tolerance	Remark
R1, R2	1.5Ω	±2%	
C1, C2	100pF	±2%	
C3, C4	56pF	±2%	
C5, C6	230pF	±2%	Use 220pF + 10pF

8.4 Configuring the M519 for the actual antenna

Different antenna have a different impedance and different RF characteristics. The PN5190 NFC/RFID HF frontend IC in the M519 must be configured, in order to adapt its behaviour to the very antenna that it is driving.

The settings for the three compliant antennas developed by SpringCard are stored in the firmware of the M519:

- 69x45mm balanced antenna (foundation of the M519-SUV product, and available as ANT-S6945 in the M519-SRK),
- 25x25mm balanced antenna (ANT-S2525 in the M519-SRK),
- 80x80mm balanced antenna (ANT-S8080 in the M519-SRK).

When the M519 is delivered, the settings for the 69x45mm balanced antenna are selected.

Therefore, the integrator must explicitly activate different settings if a different antenna is used in the final design. Refer to chapter 7.2 in [PMU23103] for comprehensive instructions on this matter.

Warning: Using the M519 with an antenna that is not coherent with the settings of the PN5190:

- breaks compliance with ISO/IEC 14443 and 15693 and give an inconsistent operating range
- is likely to break CE/FCC conformity as well
- causes overheating of the module, of the antenna and/or of the matching circuit.

8.5 In-the-field RF optimization

To be written. The corresponding feature is not yet implemented in the current version of the firmware.

9 Integration Guide – Contact smart card

The M519 features a smart card interface on its pin 10 to 14. The firmware is developed to be compliant with ISO/IEC 7816-3 at protocol level (T=0 and T=1), and with EMV Contact specification for the L1 digital part⁴.

To be fully compliant with these standards (ISO/IEC 7816-3 electrical part, EMV Contact for the L1 analog part), a suitable physical smart card interface must be added to the design.

The M519 supports two different ICs to implement the smart card hardware:

- The NXP TDA8035, a single-slot smart card interface IC, that can drive one SIM/SAM card. See § 9.2 for reference on using the M519 with a TDA8035.
- The NXP TDA8026, a multiple-slot smart card interface IC, that can drive up to five cards. See § 9.3 for reference on using the M519 with a TDA8026.

TDA8035 and TDA8026 offer full compliance with the standards and cover all the power classes for the smart cards: class A (5V), class B (3.3V) and class C (1.8V). They implement ESD protections that are required for any system where the user may insert or remove the smart card.

For systems where the smart card is affixed to the PCB (typically when the “smart card” is a secure element in the form of an SMD IC and not actually a card), ESD protections and the support of many power levels are not mandatory. In this situation, it is possible to connect the “smart card” directly to the pins of the M519. See § 9.1 for reference on this use case.

4 The M519 being an OEM device, actual compliance with the standard and specifications is not asserted. Compliance tests and complete certifications could be performed on a “final”, assembled product only.

9.1 Single slot, direct access

9.1.1 Overview

It is possible to connect a smart card directly to the M519, without any physical smart card interface IC, provided that the smart card operates at 3.3V and no ESD protection is required. Use this design to add an SMD secure element to your product with no extra costs.

9.1.2 Guidelines

The direct access smart card interface is implemented as follow:

- Connect /SC_IRQ to Ground,
- Connect SC_IO to the IO signal on the smart card,
- Connect SC_CLK to the CLK signal on the smart card (the M519 provides a 4MHz clock),
- Connect SC_RST to the RST signal on the smart card,
- Use SC_VCC to control the smart card power (voltage is up when SC_VCC is high). You may use VOUT as power source.

9.1.3 Reference schematics

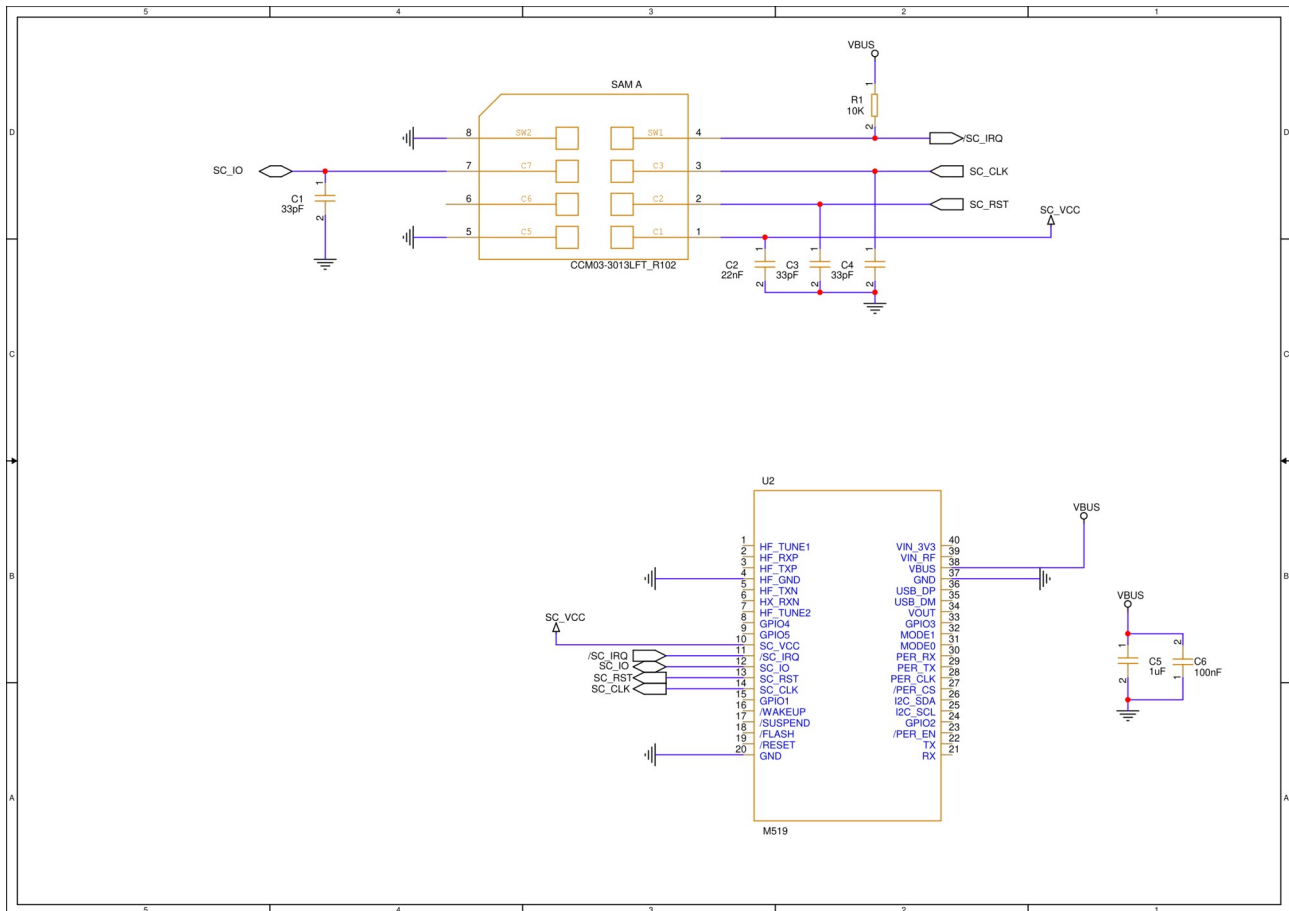

Figure 10: Reference schematics, single slot, direct access

9.1.4 Firmware implementation / PC/SC slot

Internally, the single slot is slot #1 (#0 is not used). Use this page to configure it:

https://docs.springcard.com/books/SpringCore/Non_volatile_memory/Configuration/Smartcards/First_ID_000_slot

(Of course, the power class settings is ignored in this design, since the hardware is limited to 3.3V only)

On the PC/SC interface, the slot is named “M519 SAM” (without a letter, unless the letter is enforced by configuration).

9.1.5 Card tracking

This design does not provide card tracking (the M519 has no way to be notified if the card is inserted or removed). Make sure that the card is already present when the M519 starts, and remains present all the time.

9.2 Single ID-000 slot, using TDA8035

9.2.1 Overview

NXP TDA8035 is a low-power, single-slot analogue smart card interface. It is the best solution to associate one ID-000 slot to the M519, when the product being designed must support one SIM/SAM card (typically for public transport or closed-loop payment applications).

For details, please consult the data sheet at NXP's:

<https://www.nxp.com/products/security-and-authentication/contact-readers/high-integrated-and-low-power-smart-card-interface:TDA8035HN>

9.2.2 Guidelines

The TDA8035 is normally driven by I/O signals, but to limit the number of signal lines between the M519 and the board with the ID-000 slot, the TDA8035 has to be associated to a 4-bit I²C I/O expander (NXP PCA9536, I²C address μ 41). The PCA9536DP also let the M519 detect the presence of the slot.

This interface is implemented as follow:

- Connect /SC_IRQ to OFFn on the TDA8035,
- Connect SC_IO to IOUC on the TDA8035,
- Connect SC_CLK to X1 on the TDA8035 (the M519 provides a 4MHz clock), leave X2 unconnected, set CDIV1 and CDIV2 to select a 1:1 clock divider,
- Connect SC_RST to RST on the TDA8035,

- Leave SC_VCC unconnected (the M519 will drive the VCC signal of the card through I²C only; respect exactly the reference schematics in § 9.2.3 to connect the PCA9536 and the TDA8035 correctly),
- Use VOUT to power the PCA9536 and the digital part of the TDA8035; its analog part may be powered by another source.

9.2.3 Reference schematics

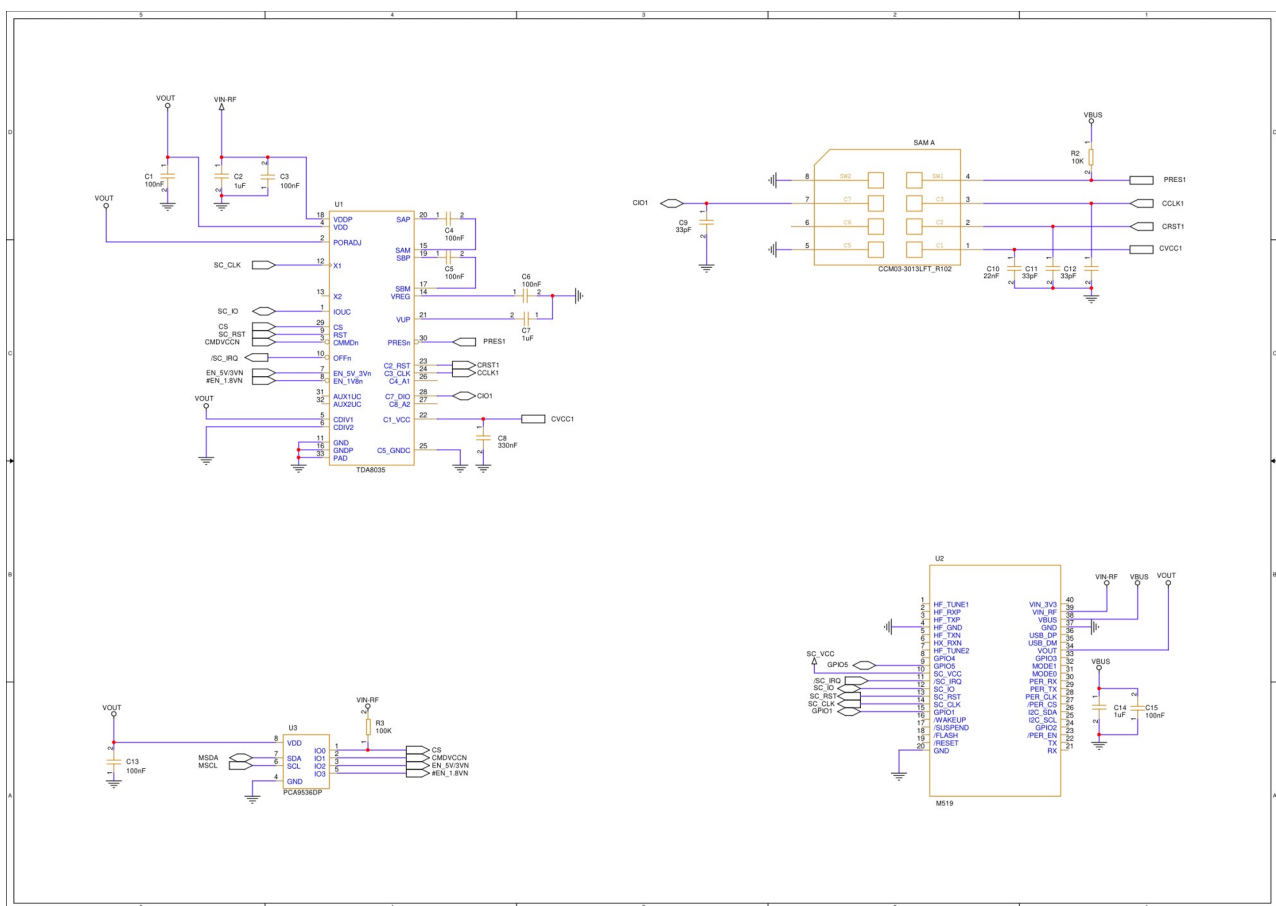

Figure 11: Reference schematics, single ID-000 slot, using TDA8035

9.2.4 Firmware implementation / PC/SC slot

Internally, the single slot is slot #1 (#0 is not used). Use this page to configure it:

https://docs.springcard.com/books/SpringCore/Non_volatile_memory/Configuration/Smartcards/First_ID_000_slot

On the PC/SC interface, the slot is named “M519 SAM” (without a letter, unless the letter is enforced by configuration).

9.2.5 Card tracking

Thanks to the OFFn signal of the TDA8035 connected to /SC_IRQ, the M519 is notified of card insertion or removal. This let the M519 report the actual card status to the application.

9.3 One ID-1 and four ID-000 slots, using TDA8026

9.3.1 Overview

NXP TDA8026 is an analogue interface for addressing multiple smart card slots from a single controller. It is the best solution to add to associate four ID-000 slot to the M519, when the product being designed must support a few SIM/SAM cards (typically for public transport applications with more than one network instance) and/or support one ID-1 slot for “full-size” smart cards (typically for card issuing applications or card printers).

For details, please consult the data sheet at NXP's:

<https://www.nxp.com/products/security-and-authentication/contact-readers/multiple-smart-card-slot-interface:TDA8026ET>

9.3.2 Guidelines

The TDA8026 is driven by I²C. Its addresses must be $_{H22}$, $_{H23}$ and $_{H26}$.

This interface is implemented as follow:

- Connect /SC_IRQ to IRQn on the TDA8026,
- Connect SC_IO to IOUC1 and IOUC2 on the TDA8026,

- Connect SC_CLK to CLKIN1 and CLKIN2 on the TDA8026 (the M519 provides a 16MHz clock⁵), leave X2 unconnected, set CDIV1 and CDIV2 to select a 1:1 clock divider,
- Connect SC_RST to SDWNN on the TDA8026 (the M519 will drive the RST signal of the card through I²C only),
- Leave SC_VCC unconnected (the M519 will drive the VCC signal of the card through I²C only),
- Use VOUT to power the PCA9536 and the digital part of the TDA8026; its analog part may be powered by another source.

5 The smart cards will be clocked at 4MHz. Using an input clock at 16MHz associated to a 1:4 divider is required for EMV compliance (using a 4MHz clock with a 1:1 divider is OK for ISO but not for EMV).

9.3.3 Reference schematics

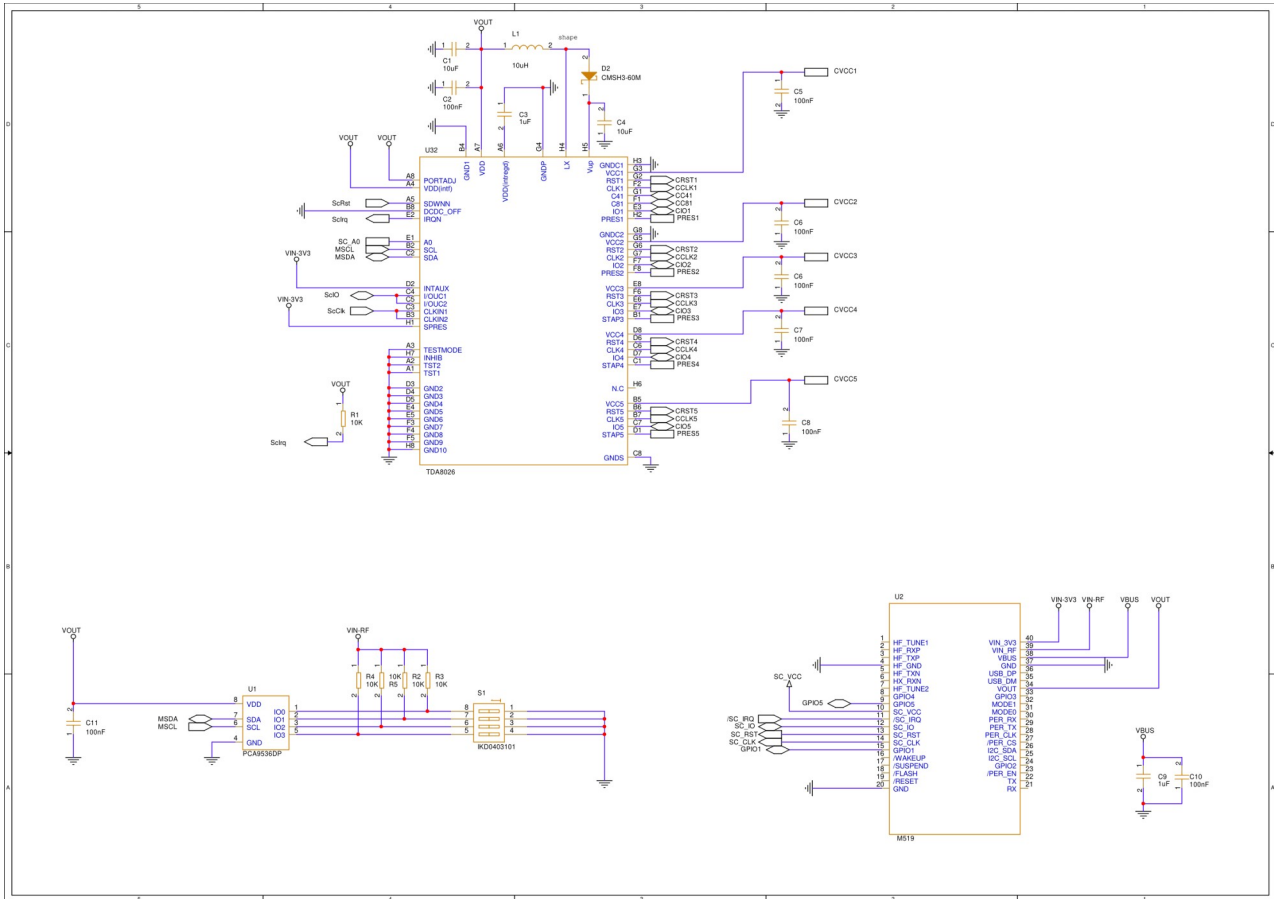

Figure 12: Reference schematics with one ID-1 and four ID-000 slots, using TDA8026, page 1 (TDA8026 and M519)

9.3.3.1 Page 2 : smart card and SAM slots

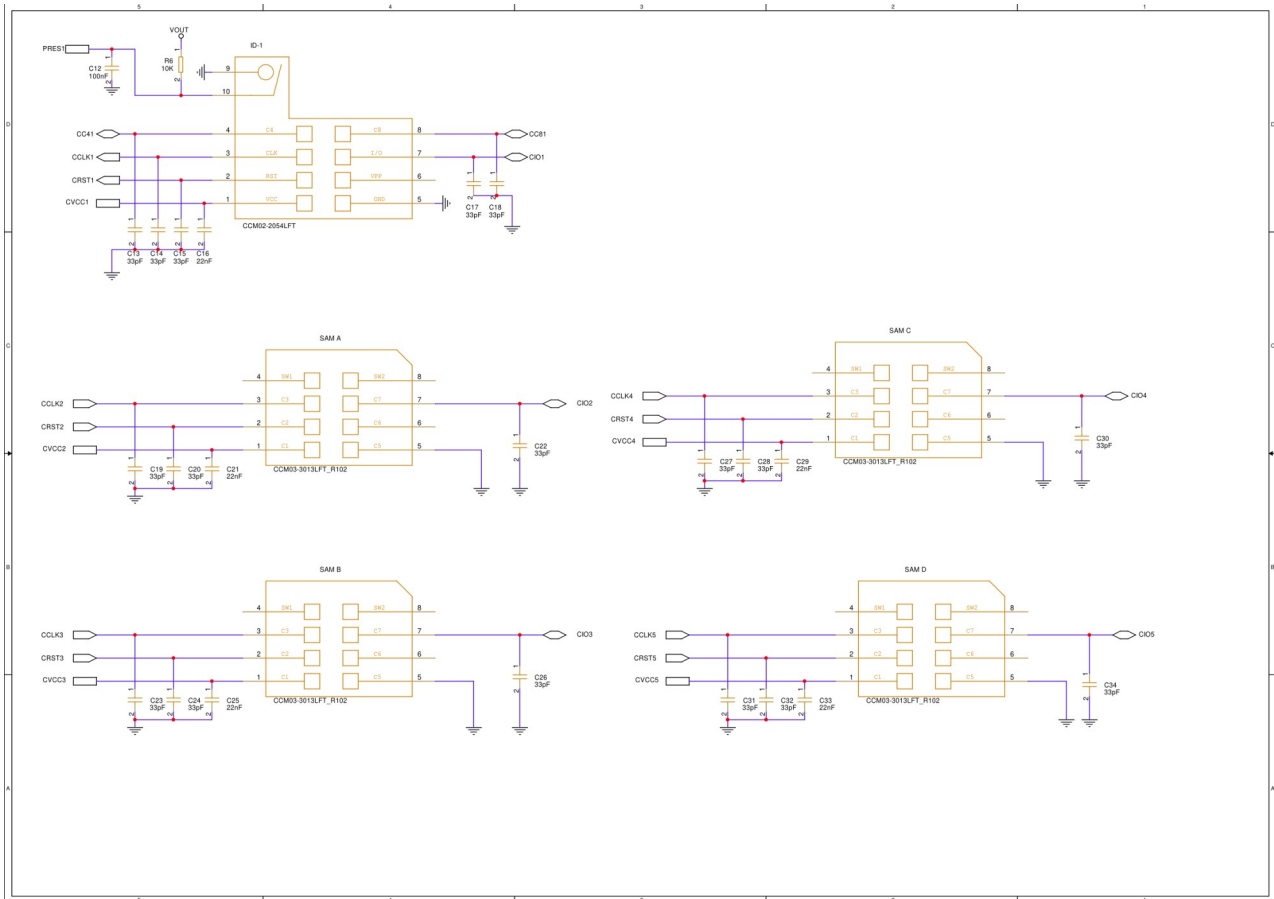

Figure 13: Reference schematics with one ID-1 and four ID-000 slots, using TDA8026, page 2 (slots)

9.3.4 Firmware implementation / PC/SC slots

9.3.4.1 Correspondence between slot numbers and names

Slot # for the TDA8026 and on the schematics	Slot number in the firmware	Slot type	Slot name when used with SpringCard driver for Windows	How to configure this slot?
#1 (CVCC1, CIO1, etc)	0	ID-1	M519 Contact	See § 9.3.4.2
#2 (CVCC2, CIO2, etc)	1	ID-000	M519 SAM A	See § 9.3.4.3
#3 (CVCC3, CIO3, etc)	2	ID-000	M519 SAM B	See § 9.3.4.4
#4 (CVCC4, CIO4, etc)	3	ID-000	M519 SAM C	See § 9.3.4.4
#5 (CVCC5, CIO5, etc)	4	ID-000	M519 SAM D	See § 9.3.4.4

9.3.4.2 ID-1 slot

Refer to this page to configure the ID-1 “M519 Contact” slot:

https://docs.springcard.com/books/SpringCore/Non_volatile_memory/Configuration/Smartcards/Main_slot

9.3.4.3 ID-000 slot A

Refer to this page to configure the first ID-000 “SAM A” slot:

https://docs.springcard.com/books/SpringCore/Non_volatile_memory/Configuration/Smartcards/First_ID_000_slot

The presence switch of this slot allows the TDA8026 to generate an interrupt every time a SIM/SAM card is inserted or removed. This make it possible for the M519 to notify the host quickly on any change. The TDA8026 also ensures that the slot is immediately powered off when the SIM/SAM card is being removed, hence avoiding the risk of a short-circuit over the slot contacts.

9.3.4.4 ID-000 slots B, C, D

Refer to this page to configure the other ID-000 slots (“M519 SAM B”, “M519 SAM C” and “M519 SAM D”) globally:

https://docs.springcard.com/books/SpringCore/Non_volatile_memory/Configuration/Smartcards/Other_ID_000_slots

On the PC/SC interface, these slots are named “M519 SAM B”, “M519 SAM C” and “M519 SAM D” respectively.

9.3.5 Card tracking, emergency power down

On the ID-1 “M519 Contact” slot and on the first ID-000 “M519 SAM A” slots, the internal logic of the TDA8026 monitors the presence and generates an interrupt every time a smart card is inserted or removed. This make it possible for the M519 to notify the host quickly on any change. The TDA8026 also ensures that the slot is powered down immediately when the smart card is being removed, hence avoiding the risk of a short-circuit at the slot contacts.

On the other hand, the other ID-000 slots (“M519 SAM B”, “M519 SAM C” and “M519 SAM D”) are not automatically monitored by the TDA8026. As a consequence, the M519 can't notify the host when a SIM/SAM card is inserted or removed; to be usable, a card must be placed in the slot before starting the module, and stay in place till the module is stopped. More than that, the slot remains powered up when the card is removed, which is likely to create a short-circuit between the VCC line and other signals of the card, or between the VCC line and the metallic part of the slot. **To prevent any issue, make sure, when designing the final product, that the M519 and the TDA8026 are totally powered off every-time the user opens the shell to access these slots.**

9.3.6 Disabling unmounted/unused slots

When the M519 detects that it has a TDA8026 as peripheral on its I²C bus, the module assumes that it has five slots (one ID-1 and four ID-000). This is not always the case: the final design may have only one ID-1 and one ID-000, or four ID-000 and no ID-1, or even one ID-1 only.

In this situation, it is advised to let the module disable the slots that are actually not wired. There are two ways to do so: by adding some hardware, or by configuration.

9.3.6.1 Hardware

Add a NXP PCA9536 to the design (4-bit I²C I/O expander, I²C address _H41). If both a TDA8026 and a PCA9536 are present, the M519 implements the following rules:

- IO0 on PCA9536 tied to a LOW level → slot #0 (ID-1, “M519 Contact”) is removed.
- IO1 on PCA9536 tied to a LOW level → slot #1 (ID-000, “M519 SAM A”) is removed.
- IO2 on PCA9536 tied to a LOW level → slots #2, #3 and #4 (ID-000, “M519 SAM B”, “M519 SAM C” and “M519 SAM D”) are removed.
- IO3 on PCA9536 tied to a LOW level → slot #1 is ID-1, not ID-000 (slot #1 is “M519 Contact B”; slot #0 becomes “M519 Contact A”, slot #2 becomes “M519 SAM A”, etc).

9.3.6.2 Configuration

When the M519 is configured for PC/SC mode, use this configuration register to manage the list of slots:

https://docs.springcard.com/books/SpringCore/Non_volatile_memory/Configuration/PC_SC/Slot_listing

9.4 Smart card interface detection algorithm

When starting-up, the M519 uses the following algorithm to detect the smart card interface:

- If SC_RST is tied to ground (forced LOW level) on startup, then the smart card subsystem is totally disabled⁶,
- Else, if /SC_IRQ is asserted (LOW level) on startup, then the presence of a smart card in direct connection is assumed (§ 9.1).
- Else, if a NXP TDA8026 is found on the I²C bus, then this interface is activated (§ 9.3). SC_CLK is activated at 16MHz to feed the TDA8026. A PCA9536 may be used to manage the list of slots (§ 9.3.6.2).

6 This to allow connecting a NXP PCA9536 to the I²C bus of the M519 without activating the TDA8035 support logic. This is used in the M519-SUV, where the PCA9536 controls the serial interface.

- Else, if a NXP PCA9536 is found the I²C bus (but no TDA8026), then the presence of a TDA8035 is assumed (§ 9.2). SC_CLK is activated at 4MHz to feed the TDA8035.

Legal Information

DISCLAIMER

This document is provided for informational purposes only and shall not be construed as a commercial offer, a license, an advisory, fiduciary or professional relationship between SPRINGCARD and you. No information provided in this document shall be considered a substitute for your independent investigation. The information provided in the document may be related to products or services that are not available in your country.

This document is provided "as is" and without warranty of any kind to the extent allowed by the applicable law. While SPRINGCARD will use reasonable efforts to provide reliable information, we don't warrant that this document is free of inaccuracies, errors and/or omissions, or that its content is appropriate for your particular use or up to date. SPRINGCARD reserves the right to change the information at any time without notice.

SPRINGCARD doesn't warrant any results derived from the use of the products described in this document. SPRINGCARD will not be liable for any indirect, consequential or incidental damages, including but not limited to lost profits or revenues, business interruption, loss of data arising out of or in connection with the use, inability to use or reliance on any product (either hardware or software) described in this document.

These products are not designed for use in life support appliances, devices, or systems where malfunction of these products may result in personal injury. SPRINGCARD customers using or selling these products for use in such applications do so on their own risk and agree to fully indemnify SPRINGCARD for any damages resulting from such improper use or sale.

INFORMATION ABOUT THE BRAND

SPRINGCARD, the SPRINGCARD logo are registered trademarks of SPRINGCARD SAS. All other brand names, product names, or trademarks belong to their respective holders. Information in this document is subject to change without notice. Reproduction without written permission of SPRINGCARD is forbidden.

COPYRIGHT NOTICE

All information in this document is either public information or is the intellectual property of SPRINGCARD and/or its suppliers or partners.

You are free to view and print this document for your own use only. Those rights granted to you constitute a license and not a transfer of title : you may not remove this copyright notice nor the proprietary notices contained in these documents, and you are not allowed to publish or reproduce this document, either on the web or by any means, without written permission of SPRINGCARD.

Copyright © SPRINGCARD SAS 2023, all rights reserved.

EDITOR'S INFORMATION

SPRINGCARD SAS company with a capital of 227 000 €
RCS EVRY B 429 665 482
Parc Gutenberg, 2 voie La Cardon
91120 Palaiseau – FRANCE

CONTACT

For more information and to locate our sales office or distributor in your country or area, please visit www.springcard.com